

Apple II

Extended 80-Column
Text Card Supplement
For IIe Only

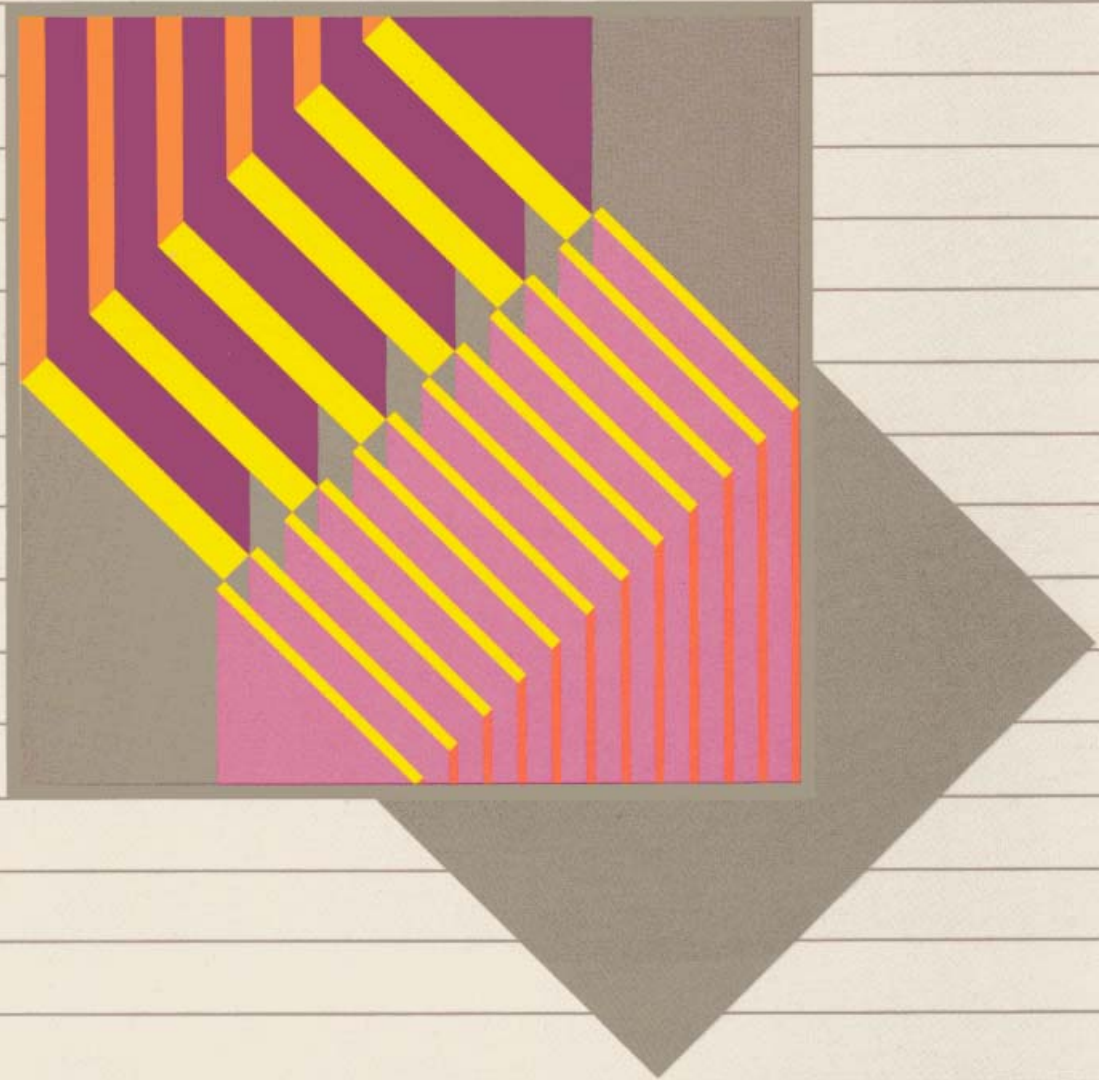

Notice

Apple Computer, Inc. reserves the right to make improvements in the product described in this manual at any time and without notice.

Disclaimer of All Warranties and Liabilities

Apple Computer, Inc. makes no warranties, either express or implied, with respect to this manual or with respect to the software described in this manual, its quality, performance, merchantability, or fitness for any particular purpose. Apple Computer, Inc. software is sold or licensed "as is." The entire risk as to its quality and performance is with the buyer. Should the programs prove defective following their purchase, the buyer (and not Apple Computer, Inc., its distributor, or its retailer) assumes the entire cost of all necessary servicing, repair, or correction and any incidental or consequential damages. In no event will Apple Computer, Inc. be liable for direct, indirect, incidental, or consequential damages resulting from any defect in the software, even if Apple Computer, Inc. has been advised of the possibility of such damages. Some states do not allow the exclusion or limitation of implied warranties or liability for incidental or consequential damages, so the above limitation or exclusion may not apply to you.

This manual is copyrighted. All rights are reserved. This document may not, in whole or part, be copied, photocopied, reproduced, translated or reduced to any electronic medium or machine readable form without prior consent, in writing, from Apple Computer, Inc.

© 1982 by Apple Computer, Inc.
20525 Mariani Avenue
Cupertino, California 95014
(408) 996-1010

The word Apple and the Apple logo are registered trademarks of Apple Computer, Inc.

Simultaneously published in the U.S.A and Canada.

Written by Allen Watson of the Apple PCSD
Publications Department



Warning

This equipment has been certified to comply with the limits for a Class B computing device, pursuant to Subpart J of Part 15 of FCC Rules. Only peripherals (computer input/output devices, terminals, printers, etc.) certified to comply with the Class B limits may be attached to this computer. Operation with non-certified peripherals is likely to result in interference to radio and TV reception.

Apple II

Extended 80-Column
Text Card Supplement

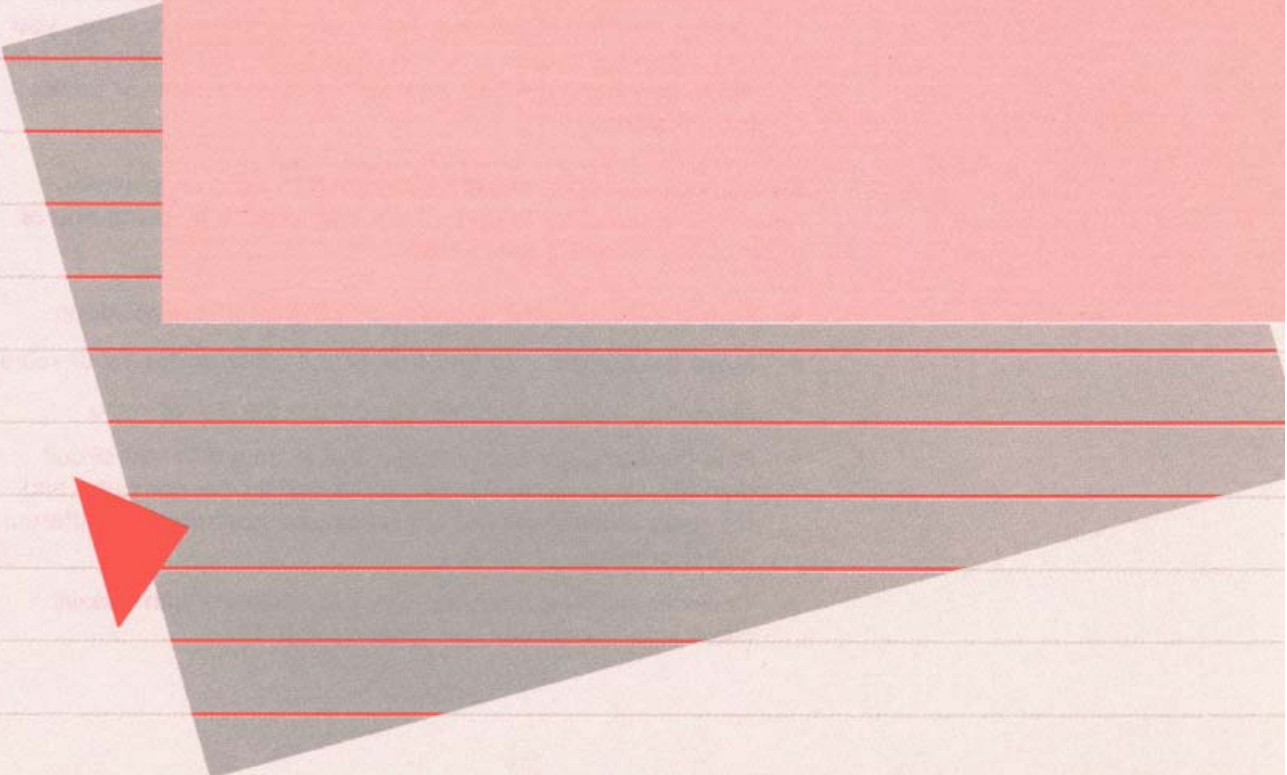
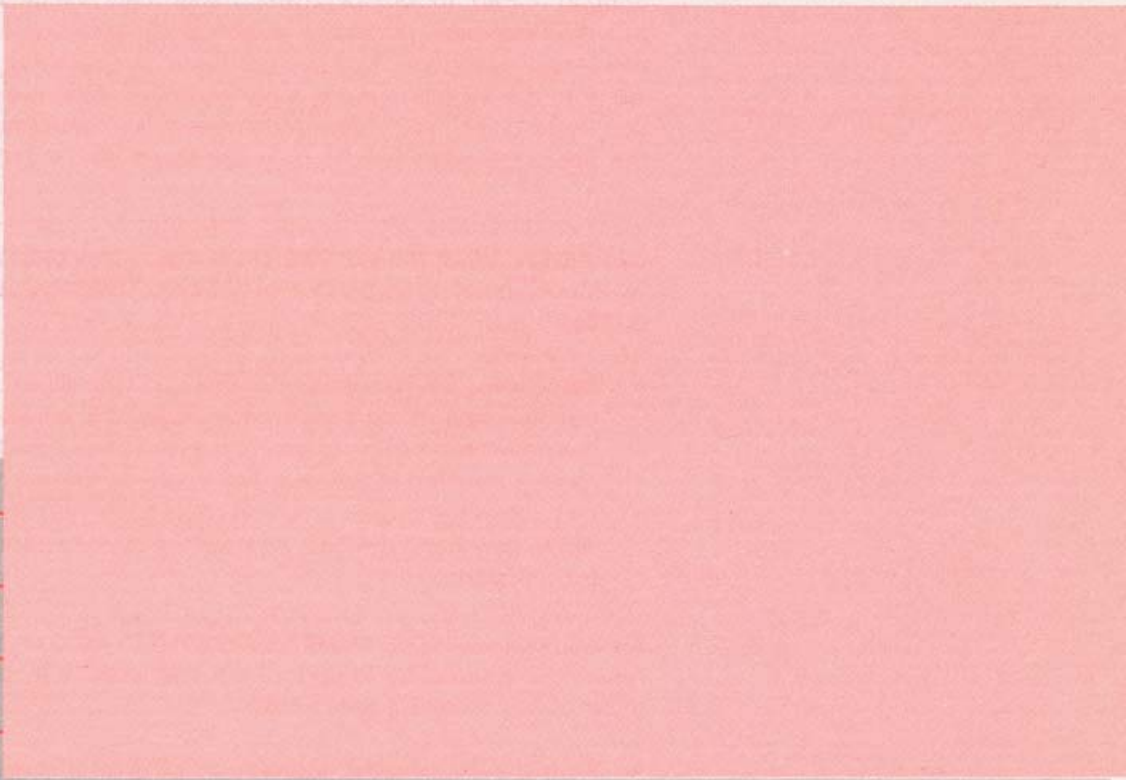

Radio and Television Interference

The equipment described in this manual generates and uses radio-frequency energy. If it is not installed and used properly, that is, in strict accordance with our instructions, it may cause interference with radio and television reception.

This equipment has been tested and complies with the limits for a Class B computing device in accordance with the specifications in Subpart J, Part 15, of FCC rules. These rules are designed to provide reasonable protection against such interference in a residential installation. However, there is no guarantee that the interference will not occur in a particular installation, especially if you use a "rabbit ear" television antenna. (A "rabbit ear" antenna is the telescoping-rod type usually contained on TV receivers.)

You can determine whether your computer is causing interference by turning it off. If the interference stops, it was probably caused by the computer or its peripheral devices. To further isolate the problem:

- Disconnect the peripheral devices and their input/output cables one at a time. If the interference stops, it is caused by either the peripheral device or its I/O cable. These devices usually require shielded I/O cables. For Apple peripheral devices, you can obtain the proper shielded cable from your dealer. For non-Apple peripheral devices, contact the manufacturer or dealer for assistance.

If your computer does cause interference to radio or television reception, you can try to correct the interference by using one or more of the following measures:

- Turn the TV or radio antenna until the interference stops.
- Move the computer to one side or the other of the TV or radio.
- Move the computer farther away from the TV or radio.
- Plug the computer into an outlet that is on a different circuit than the TV or radio. (That is, make certain the computer and the radio or television set are on circuits controlled by different circuit breakers or fuses.)
- Consider installing a rooftop television antenna with coaxial cable lead-in between the antenna and TV.

If necessary, you should consult your dealer or an experienced radio/television technician for additional suggestions. You may find helpful the following booklet, prepared by the Federal Communications Commission:

"How to Identify and Resolve Radio-TV Interference Problems"

This booklet is available from the U.S. Government Printing Office, Washington, DC 20402, stock number 004-000-00345-4.

Table of Contents

	<i>Who Needs To Read This Supplement?</i>	
	vii Users: A Card Is a Card	
	viii Developers: How To Use the Auxiliary Memory	
	viii Contents of This Supplement	
	ix Symbols Used in This Supplement	
1	<i>Introduction</i>	3
	3 Installation	
	4 80-Column Features	
	4 About the Auxiliary Memory	
2	<i>How the Auxiliary Memory Works</i>	7
	7 Addressing the Auxiliary Memory	
	9 How the 80-Column Display Works	
	11 Double High-Resolution Graphics	
3	<i>How To Use the Auxiliary Memory</i>	15
	16 The Extended Display	
	16 Display Pages	
	17 Display Mode Switching	
	18 Addressing the 80-Column Display Directly	
	21 Auxiliary Memory Switching	
	21 Switching the 48K Bank	
	25 Switching High Memory, Stack, and Zero-Page	
	29 Auxiliary-Memory Subroutines	
	29 Moving Data To Auxiliary Memory	
	30 Transferring Control To Auxiliary Memory	

Programming Examples

33

- 35 Identifying Different Configurations
- 37 Apple IIe Identification in Assembly Language
- 40 Apple IIe Identification from BASIC
- 41 Apple IIe Identification from Pascal
- 43 Storing Graphics Pages from Applesoft
- 46 Storing Data Strings from Pascal

Index

53

Schematic Diagram

59

Who Needs To Read This Supplement?

This supplement comes with the Apple IIe Extended 80-Column Text Card and describes the added features it has, compared to the 80-Column Text Card. Before reading this supplement, you should read the *Apple IIe 80-Column Text Card Manual*.

There are two ways you are likely to use the extended version of the 80-Column Text Card:

- As a user with application programs that take advantage of the extra memory on the card to give you more features or more storage for your data.
- As a developer creating a program, for yourself or for others, that will use the extra storage the extended card provides.

Users: A Card Is a Card

From the user's point of view, the Extended 80-Column Text Card is just like the standard 80-Column Text Card. Oh, it's a little bigger, and it costs more, but the technical differences between the two kinds of text cards are mostly hidden by software. Read Chapter 1 of this supplement for an introduction to the Apple IIe 80-Column Extended Text Card.

The extended text card is installed the same way as the standard 80-column card: read the *Apple IIe 80-Column Text Card Manual* for directions.

Most application programs run the same with either card—in fact, many of them don't even take advantage of the extra memory on the extended card; they simply use it to display 80 columns of text. Programs that do use the extra memory may do so automatically, without any action on your part, or they may let you select optional features or data storage. To find out how to use those programs with the extra memory, refer to their instruction manuals.

In short, if you just want to use this card for displaying 80 columns of text, and you aren't developing a program that uses the auxiliary memory, all you really need to know can be found in the *Apple IIe 80-Column Text Card Manual* and in the instructions for your application programs.

Developers: How To Use the Auxiliary Memory

The only difference between the Extended 80-Column Text Card and the standard 80-Column Text Card is the amount of memory they contain. The extended card has 64K bytes of auxiliary memory, while the standard card has only the additional 1K bytes necessary to display 80 columns of text on an Apple IIe.

The main purpose of this supplement is to provide you with enough information to use the auxiliary memory in your programs. Normally, programs used with the Apple IIe can only work with the 64K bytes of built-in main memory. To work with the auxiliary memory, a program must set special switches in the Apple IIe that substitute auxiliary memory for main memory. Neither DOS 3.3 nor Pascal 1.1—system programs for the Apple II—support this memory substitution, so for now your application programs have to handle it themselves.

Contents of This Supplement

This supplement contains the information you need to use the auxiliary memory for storing programs and data. Chapter 1 is a general introduction; it describes the functions of the Extended 80-Column Text Card.

Chapter 2 is a general description of the design of the Extended 80-Column Text Card; it explains how the card works with the Apple IIe hardware.

Chapter 3 contains directions for using the auxiliary memory with your programs. Most of the information in Chapter 3 is adapted from the *Apple IIe Reference Manual*. The reference manual is your main source of information about the internal operation of the Apple IIe.

Chapter 4 contains short programs that use the auxiliary memory. These examples are functional, but not general: you will probably want to modify them for use in the programs you write.

Symbols Used in This Supplement

Special text in this manual is set off in different ways, as shown in these examples.



Warning

Important warnings appear in boxes like this.

Reminder: Information that is only incidental to the text appears in gray boxes like this. You may want to skip over such boxes and return to them later.

Captions, definitions, and other short items appear in **marginal glosses** like this.

Introduction

-
- 3 Installation
 - 4 80-Column Features
 - 4 About the Auxiliary Memory

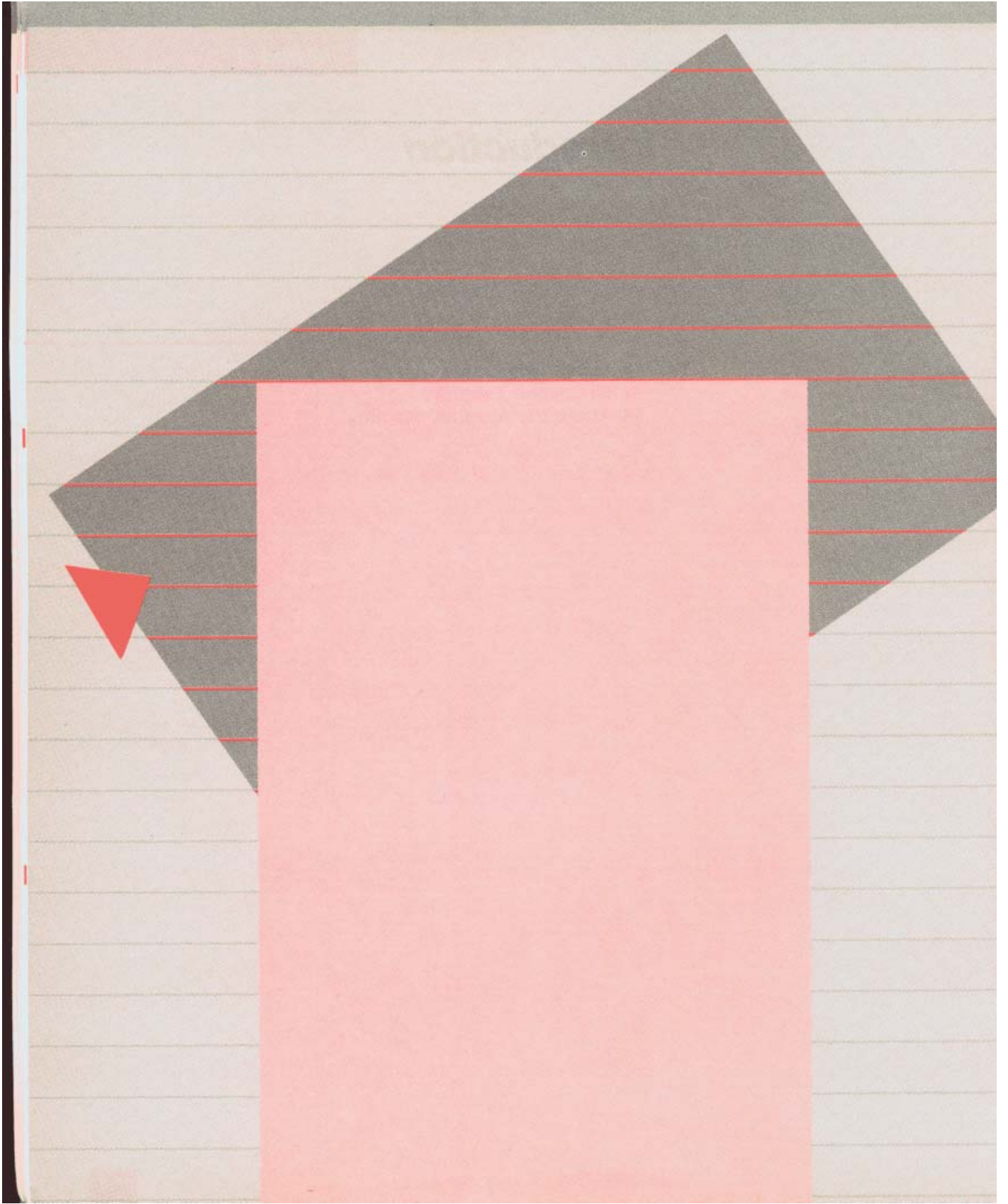

Introduction

The design of the Apple IIe Extended 80-Column Text Card is the same as that of the standard Apple IIe 80-Column Text Card. The only difference is that the extended text card contains 64K bytes of auxiliary memory (programmable memory or RAM) while the standard card contains only 1K byte of RAM. The 80-column display requires only 1K byte of auxiliary memory, so it will work with either card. The firmware that supports the special features associated with the 80-column display is part of the Apple IIe itself, and works the same regardless of which card is present.

Installation

Installing the Extended 80-Column Text Card is easy: do it just the way you install the standard 80-Column Text Card. Either card fits into the auxiliary slot (labeled `AUX. CONNECTOR`) on the main logic board inside the Apple IIe. If you haven't installed the card yet, follow the directions given in the *Apple IIe 80-Column Text Card Manual*.



Warning

Never install or remove anything inside the Apple IIe with the power on. There is a small red lamp—an LED—toward the back of the main circuit board to remind you of this; if the red lamp is on, turn off the power before you do anything inside the Apple IIe.

80-Column Features

The built-in firmware that supports the 80-column display has other features in addition to the wider display. The *Apple IIe 80-Column Text Card Manual* tells you how to activate the built-in firmware and the 80-column display. That manual also describes many of the Apple IIe's features.

You can find more information about the Apple IIe in the *Apple IIe Reference Manual*. Chapter 2 includes a description of the different display modes and how to select them. Chapter 3 includes tables of the functions of the escape sequences and control keys in the Apple IIe.

About the Auxiliary Memory

The Extended 80-Column Text Card has 64K bytes of additional RAM, usually referred to as auxiliary memory. A 1K-byte area of this memory serves the same purpose as the memory on the 80-Column Text Card: expanding the text display to 80 columns. The other 63K bytes can be used for auxiliary program and data storage. If you use only 40 columns for text display, all 64K bytes are available for programs and data.

The processor in the Apple IIe can only address 64K bytes of memory. The computer has special circuits that programs can switch to access auxiliary memory in place of main memory. At any one time, locations in the same 64K address space are in either main memory or auxiliary memory. In other words, even though an Apple IIe with an Extended 80-Column Text Card has a total of 128K bytes of programmable memory, it is not appropriate to call it a 128K-byte system. Rather, there are 64K bytes of auxiliary memory that can be swapped for main memory under program control.



Warning

Careless switching to the auxiliary memory is almost certain to crash your programs. If you want to use auxiliary memory in your own programs, be sure to study the rest of this supplement and the relevant information in the *Apple IIe Reference Manual*.

How the Auxiliary Memory Works

-
- 7 Addressing the Auxiliary Memory
 - 9 How the 80-Column Display Works
 - 11 Double High-Resolution Graphics

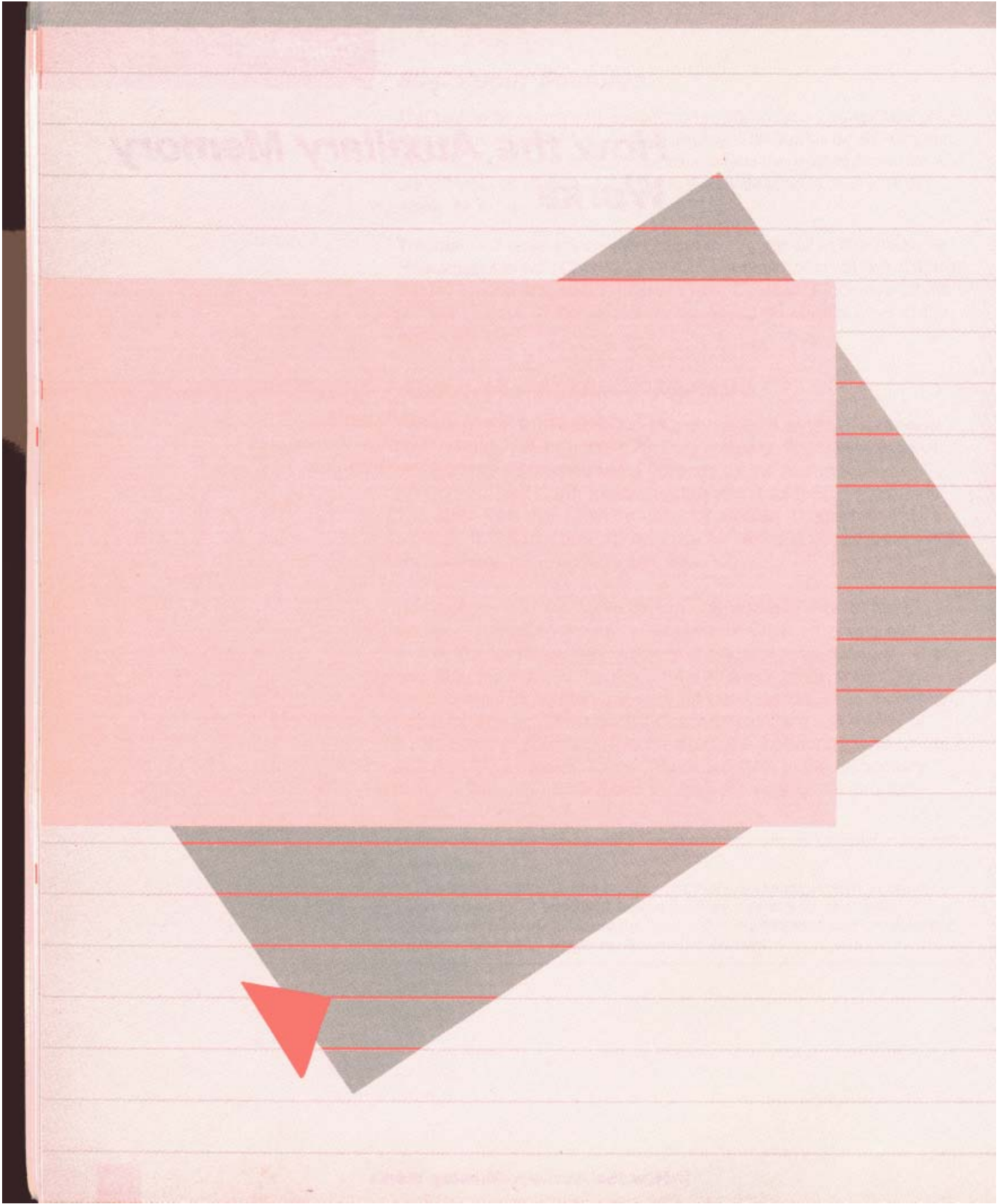

How the Auxiliary Memory Works

This chapter briefly outlines how the auxiliary memory operates. It will help you understand what happens when you use the auxiliary memory in your programs.

Addressing the Auxiliary Memory

The 6502 microprocessor can address 64K bytes of memory. In the Apple IIe the microprocessor's entire 64K memory space is taken up by main RAM (random-access memory), ROM (read-only memory), and I/O (input/output); there's no memory space available for the added memory on the extended text card. Instead, the address bus is connected to the auxiliary memory in parallel with the main memory. To use the auxiliary memory for program and data storage, the Apple IIe switches its data bus so that it reads and writes to the memory on the card instead of the main memory. To use the auxiliary memory to expand the display, the Apple IIe fetches data both from main memory and from auxiliary memory, as described in the section "How the 80-Column Display Works."

The bus switching for program and data storage is controlled by the Memory Management Unit (MMU), a custom integrated circuit designed for the Apple IIe (see Chapter 7 of the *Apple IIe Reference Manual*). The MMU contains the soft switches set by your programs along with the logic circuitry to monitor the address bus and to switch to auxiliary memory for the selected address ranges.

Figure 2-1. Memory Map with Auxiliary Memory

		Main Memory			Auxiliary Memory
\$ FFFF		Bank-Switched Memory			Bank-Switched Memory
\$ E000					
\$ D000					
\$ CFFF		I/O			
\$ C000					
\$ BFFF					
\$ 6000					
\$ 4000		Hi-Res Graphics Page 2			
\$ 2000		Hi-Res Graphics Page 1			Hi-Res Graphics Page 1X
\$ C00					
\$ 800		Text Page 2			
\$ 400		Text Page 1			Text Page 1X
\$ 200					
\$ 1 FF		Stack & Zero Page			Stack & Zero Page
\$ 0					

As you can see by studying the memory map in Figure 2-1, the auxiliary memory is divided into two large sections and one small one. The largest section is substituted for main memory addresses 512 to 49151 (\$200 through \$BFFF). This part of memory is sometimes referred to as the 48K memory space, and it is used for storing programs and data.

The other large section of auxiliary memory replaces main memory addresses 52K to 64K (\$D000 through \$FFFF). This memory space is called the bank-switched memory. If you plan to use this part of the auxiliary memory, read the section "Bank-switched Memory" in the *Apple IIe Reference Manual*. The switching for the ROM and the \$D000 bank is independent of the auxiliary-RAM switching, so the bank switches have the same effect on the auxiliary RAM that they do on the main RAM.

When you switch to the auxiliary memory in the bank-switched memory space, you also get the first two pages of auxiliary memory, from 0 to 511 (\$0000 through \$01FF). This part of memory contains page zero, which is used for important data and base addresses, and page one, which is the 6502 stack.



Warning

Remember that addresses in page zero and the 6502 stack switch to auxiliary memory any time you switch the bank-switched memory to auxiliary memory.

How the 80-Column Display Works

Half of the data for the 80-column display is stored in main memory in the normal text Page 1, and the other half is stored in auxiliary memory on the extended text card. The display circuitry fetches bytes of data from these two memory areas simultaneously and displays them as two adjacent characters.

Memory pages are 256 bytes long, but **display pages** are either 1024 bytes, e.g., text Page 1, or 8192 bytes, e.g., high-resolution graphics Page 1. See Chapters 2 and 4 of the *Apple IIe Reference Manual*.

The main memory and the auxiliary memory are connected to the address bus in parallel, so both are activated during the display cycle. The 40-column display uses every other clock cycle and fetches data only from main memory. The 80-column display uses the remaining clock cycles to process the additional display data from auxiliary memory.

Figure 2-2. Fetching Data for the 80-Column Display

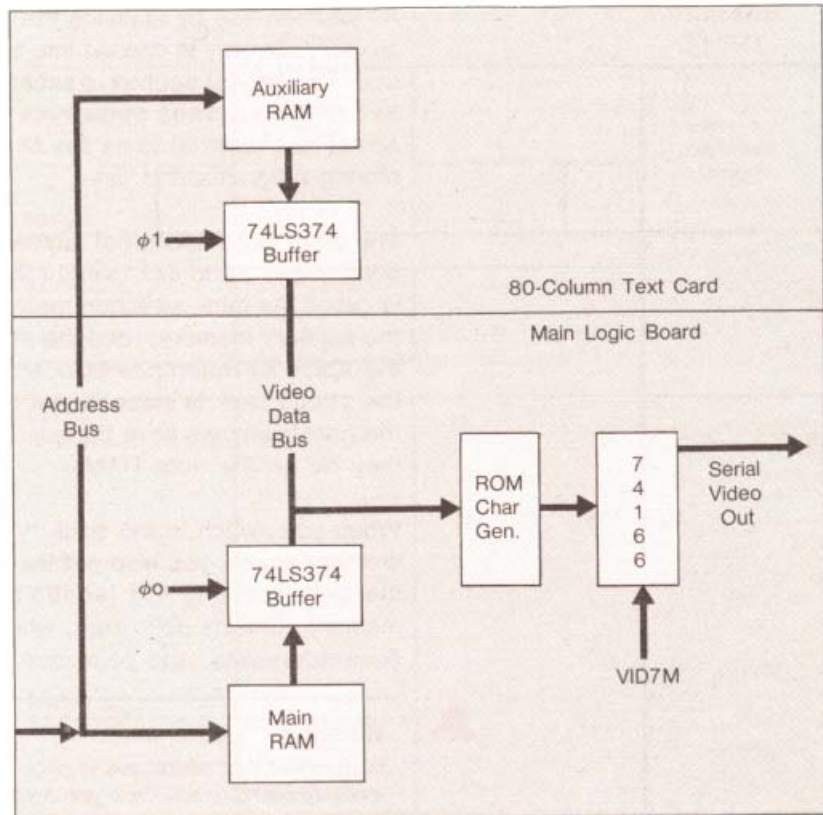

The byte of display data from main memory goes to a buffer on the main logic board, and the display data from auxiliary memory goes to a buffer on the extended text card. When the 80-column display is on, the data bytes from these buffers are switched onto the video data bus on alternate clock cycles: first the byte from the auxiliary memory, then the byte from the main memory. The main memory provides the characters displayed in the odd columns of the display, and the auxiliary memory provides the characters in the even columns.

The 80-column display contains twice as many characters as the 40-column display does, so it has to put twice as many dots across the screen. This means that the dots are clocked out at 14MHz instead of 7MHz, making them narrower and therefore dimmer on a normal video monitor. On a television set, the dot patterns making up the characters are too close together to reproduce clearly. To produce a satisfactory 80-column display requires a monitor with a bandwidth of at least 14MHz.

RGB stands for red, green, and blue, and identifies a type of color monitor that uses independent inputs for the three primary colors.

Except for some expensive RGB-type color monitors, any video monitor with a bandwidth as high as 14MHz will be a monochrome monitor. Monochrome means one color: a monochrome video monitor can have a screen color of white, green, orange, or any other single color.

Note that this simultaneous-then-sequential fetching applies only to the video-display generation; reading and writing for data storage in auxiliary memory is done by switching the data bus to read only from the card, as described in the previous section. For more information about the way the Apple IIe handles its display memory, refer to Chapter 2 and Chapter 7 of the *Apple IIe Reference Manual*.

Double High-Resolution Graphics

When you select mixed-mode graphics with 80-column text, you would expect that the doubling of the data rate that produces the 80-column display would change the high-resolution graphics from 280 to 560 dots horizontally and cause the low-resolution graphics to malfunction. To prevent this, the logic that controls the display includes an extra circuit to force the graphics displays to be the same regardless of whether you have set the soft switches for 80-column text or for 40-column text. This feature is included so that you can use 80-column text in the mixed graphics and text modes.

For those who would like to have a graphics display with twice the horizontal resolution, there is a way to disable the circuit that forces normal graphics timing with 80-column text. There are two things you must do to obtain the double high-resolution display:

- Install a jumper to connect the two Molex-type pins on the Extended 80-Column Text Card.
- Turn on the Annunciator 3 soft switch along with the switches that select the 80-column display and high-resolution graphics.

This procedure works only on the Apple IIe with the Rev B (and later) main logic board, identified by a B as the last letter of the part number on the back part of the board. Connecting the pins on the Extended 80-Column Text Card completes a connection between pin 50 (AN3) and pin 55 (FRCTXT') on the auxiliary slot.



Warning

If you have a Rev A Apple IIe, using an extended text card with a jumper makes the computer inoperable. You cannot use the double high-resolution modification with a Rev A Apple IIe.

If you have an extended text card with a jumper installed in a Rev B (or later) Apple IIe, turning on Annunciator 3 and selecting high-resolution graphics and 80-column text at the same time generates a display using high-resolution Page 1 addresses in main memory and auxiliary memory at the same time.

The memory mapping for this graphics display is doubled by columns the same way as 80-column text, but it uses high-resolution graphics Page 1 instead of text Page 1. Where the 80-column text mode displays pairs of data bytes as pairs of characters, double high-resolution mode displays pairs of data bytes as 14 adjacent dots, seven from each byte. As in 80-column text mode, there are twice as many dots across the display screen, so the dots are only half as wide.

Existing Apple II graphics programs do not support this kind of display. Until new programs become available, you'll have to write your own plotting routines if you want to use 560-dot graphics.

How To Use the Auxiliary Memory

-
- 16 The Extended Display
 - 16 Display Pages
 - 17 Display Mode Switching
 - 18 Addressing the 80-Column Display Directly
 - 21 Auxiliary Memory Switching
 - 21 Switching the 48K Bank
 - 25 Switching High Memory, Stack, and Zero-Page
 - 29 Auxiliary-Memory Subroutines
 - 29 Moving Data To Auxiliary Memory
 - 30 Transferring Control To Auxiliary Memory

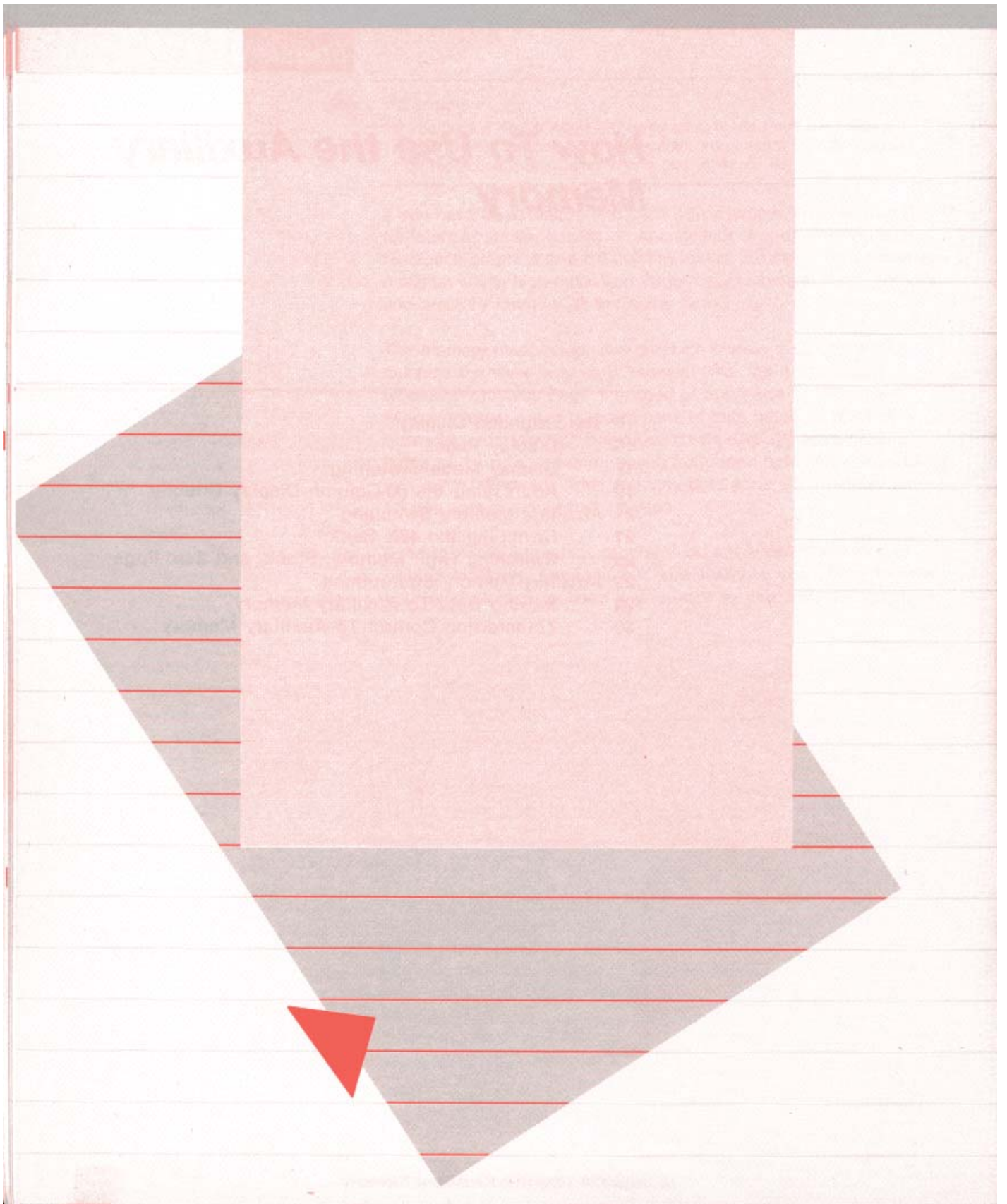

How To Use the Auxiliary Memory

This chapter describes soft switches and built-in subroutines that control the operation of the auxiliary memory. To take advantage of the additional memory, you must set up your programs to operate in one part of memory while they switch the other part between main and auxiliary RAM. Your program can perform the memory switching by means of the soft switches described in the section "Display Mode Switching" or by using the `AUXMOVE` and `XFER` subroutines described later in this chapter. Except for these subroutines, most existing Apple II system software (DOS 3.3, Pascal 1.1) doesn't support the auxiliary memory.

Although some high-level languages, such as BASIC, can set the soft switches directly, your programs must use assembly-language subroutines to control the auxiliary memory. Small assembly-language subroutines can be accessed from a BASIC program using a `CALL` statement, or they can be linked to a Pascal program as procedures or functions: see the examples in Chapter 4.



Warning

Do not attempt to use the auxiliary memory directly from a program in an interpreter language such as BASIC or Pascal. The interpreters that run such programs use several areas in main memory, including the stack and the zero page. If you switch to auxiliary memory in these pages, the interpreter crashes. When you reset the system to start over, your program and data are lost.

The Extended Display

The primary purpose of an 80-column text card is the generation of an 80-column display, so there is a complete set of switches just to control the display. Other switches are used for program and data storage in the auxiliary memory; they are described later.

Display Pages

The Apple IIe generates its video displays from data stored in specific areas in memory called display pages. The 40-column-text and low-resolution-graphics modes use text Page 1 and text Page 2, located at 1024-2047 (hexadecimal \$400-\$7FF) and 2048-3071 (\$800-\$BFF) in main memory.

The 80-column text display uses a combination of text Page 1 in main memory and the same page in the auxiliary memory, here called Page 1X. Text Page 1X occupies the same address space as text Page 1, but in auxiliary memory rather than main memory. To store data in Page 1X, you must use a soft switch (see the section "Display Mode Switching"). The built-in 80-column display routines described in Chapter 3 of the *Apple IIe Reference Manual* take care of this switching automatically; that is a good reason to use those routines for all your normal 80-column text output.

Table 3-1. Video Display Page Locations. ***Note:** These modes use locations in both main and auxiliary memory. The PAGE2 switch is used to select one or the other for storing data; see the section "Display Mode Switching."

Display Mode	Page	Lowest Address	Highest Address	Notes
40-Column Text, Low-Resolution Graphics	1	\$400 1024	\$7FF 2047	
	2	\$800 2048	\$BFF 3071	
80-Column Text	1	\$400 1024	\$7FF 2047	*
Normal 280-Dot High-Resolution Graphics	1	\$2000 8192	\$3FFF 16383	
	2	\$4000 16384	\$5FFF 24575	
Optional 560-Dot High-Resolution Graphics	1	\$2000 8192	\$3FFF 16383	*

Display Mode Switching

You select the display mode that is appropriate for your application by reading or writing to soft switches. Most soft switches have three memory locations: one for turning the switch on, one for turning it off, and one for reading the state of the switch.

Table 3-2 shows the locations of the soft switches that control the display modes. The table gives the switch locations in three forms: hexadecimal, decimal, and negative decimal. You can use the hexadecimal values in your machine-language programs. Use the decimal values in PEEK or POKE commands in Applesoft BASIC; the negative values are for Integer BASIC.

For information about the **keyboard data** and **strobe functions**, see Chapter 2 of the *Apple IIe Reference Manual*.

Some of the soft switches in Table 3-2 are marked read or write. Those soft switches share their locations with the keyboard data and strobe functions. To perform the function shown in the table, use only the operation listed there. Soft switches that are not marked may be accessed by either a read or a write. When writing to a soft switch, it doesn't matter what value you write; the switch function occurs when you address the location, and the value is ignored.



Warning

Be sure to use only the indicated operations to manipulate the switches. If you read from a switch marked write, you won't get the correct data. If you write to a switch marked read, you won't set the switch you wanted, and you may change some other switch so as to cause your program to malfunction.

When you read a soft switch, you get a byte with the state of the switch in bit 7, the high-order bit. The other bits in the byte are unpredictable. If you are programming in machine language, this bit is the sign bit. If you read a soft-switch from a BASIC program, you get a value between 0 and 255. Bit 7 has a value of 128, so if the switch is on, the value will be equal to or greater than 128; if the switch is off, the value will be less than 128.

Table 3-2. Display Soft Switches. (1) This mode is only effective when TEXT switch is off. (2) This switch has a different function when 80STORE is on: refer to the next section. (3) This switch changes the function of the PAGE2 switch for addressing the display memory on the extended text card: refer to the next section.

Name	Function	Location		Notes	
		Hex	Decimal		
TEXT	On: Display Text	\$C051	49233	-16303	
	Off: Display Graphics	\$C050	49232	-16304	
	Read TEXT Switch	\$C01A	49178	-16358	Read
MIXED	On: Text With Graphics	\$C053	49235	-16301	1
	Off: Full Graphics	\$C052	49234	-16302	1
	Read MIXED Switch	\$C01B	49179	-16357	Read
PAGE2	On: Display Page 2	\$C055	49237	-16299	2
	Off: Display Page 1	\$C054	49236	-16300	2
	Read PAGE2 Switch	\$C01C	49180	-16356	Read
HIRES	On: Graphics = High-Resolution	\$C057	49239	-16297	1
	Off: Graphics = Low-Resolution	\$C056	49238	-16298	1
	Read HIRES Switch	\$C01D	49181	-16355	Read
80COL	On: Display 80 Columns	\$C00D	49165	-16371	Write
	Off: Display 40 Columns	\$C00C	49164	-16372	Write
	Read 80COL Switch	\$C01F	49183	-16353	Read
80STORE	On: Store in Auxiliary Page	\$C001	49153	-16383	Write,3
	Off: Store in Main Page	\$C000	49152	-16384	Write,3
	Read 80STORE Switch	\$C018	49176	-16360	Read

Addressing the 80-Column Display Directly

Figure 3-1 is the map of the 80-column display. Half of the data is stored in text Page 1 in main memory, and the other half is stored in the same locations in auxiliary memory (here called Page 1X). The display circuitry fetches bytes from these two memory areas simultaneously and displays them sequentially: first the byte from the auxiliary memory, then the byte from the main memory. The main memory stores the characters in the odd columns of the display, and the auxiliary memory stores the characters in the even columns. For a full description of the way the Apple IIe handles its display memory, refer to Chapter 2 and Chapter 7 of the *Apple IIe Reference Manual*.

To store data directly into the display page on the Extended 80-Column Text Card, first turn on the `80STORE` soft switch by writing to location 49153 (negative decimal -16383 or hexadecimal `$C001`). With `80STORE` on, the page-select switch `PAGE2` switches between the portion of the 80-column display stored in Page 1 of main memory and the portion stored in Page 1X in auxiliary memory. To select Page 1X, turn the `PAGE2` soft switch on by reading or writing at location 49237 (-16299, `$C055`).

You'll have to write a short program to try out the `80STORE` and `PAGE2` soft switches. When you try to change these switches by using the Monitor program, it changes them back in the process of displaying the commands you type.

If you want to use the optional double-high-resolution display described in Chapter 2, you can store data directly into high-resolution graphics Page 1X in auxiliary memory in a similar fashion. Turn on both `80STORE` and `HIRES`, then use `PAGE2` to switch from Page 1 in main memory to Page 1X in auxiliary memory.

The memory mapping for double high-resolution graphics is similar to the normal high-resolution mapping described in Chapter 2 of the *Apple IIe Reference Manual*, with the addition of the column doubling produced by the 80-column display. Like the 80-column text mode, the double high-resolution graphics mode displays two bytes in the time normally required for one, but it uses high-resolution graphics Page 1 and Page 1X instead of text Page 1 and Page 1X.

For a description of the way the **high-order bit** acts as **color-select bit** in high-resolution displays, see Chapters 2 and 7 of the *Apple IIe Reference Manual*.

Double high-resolution graphics mode displays each pair of data bytes as 14 adjacent dots, seven from each byte. The high-order bit (color-select bit) of each byte is ignored. The auxiliary-memory byte is displayed first, so data from auxiliary memory appears in columns 0-6, 14-20, etc., up to columns 547-552. Data from main memory appears in columns 7-13, 21-27, and so on up to 553-559.

As in 80-column text, there are twice as many dots across the display screen, so the dots are only half as wide. On a TV set or low-bandwidth monitor, single dots will be dimmer than normal.

Figure 3-1. Map of 80-Column Text Display

		\$00	\$01	\$02	\$03	\$04	\$05	\$06									\$49	\$4A	\$4B	\$4C	\$4D	\$4E	\$4F				
		0	1	2	3	4	5	6									73	74	75	76	77	78	79				
MAIN MEMORY																											
AUXILIARY MEMORY		\$00	\$01	\$02	\$03	\$04	\$05	\$06	\$07									\$49	\$4A	\$4B	\$4C	\$4D	\$4E	\$4F			
		0	1	2	3	4	5	6	7									73	74	75	76	77	78	79			
\$400	1024																										
\$480	1152																										
\$500	1280																										
\$580	1408																										
\$600	1536																										
\$680	1664																										
\$700	1792																										
\$780	1920																										
\$428	1064																										
\$4A8	1192																										
\$528	1320																										
\$5A8	1448																										
\$628	1576																										
\$6A8	1704																										
\$728	1832																										
\$7A8	1960																										
\$450	1104																										
\$4D0	1232																										
\$550	1360																										
\$5D0	1488																										
\$650	1616																										
\$6D0	1744																										
\$750	1872																										
\$7D0	2000																										

Auxiliary Memory Switching

This section describes the switches used to access the auxiliary memory for storing programs and data.



Warning

The display soft switches `80STORE`, `PAGE2`, and `HIRES`, discussed here and in the previous section, are used primarily for addressing display data. These switches override the general-purpose switches described in this section, so you must set them correctly even if your program doesn't use them.

Switching the 48K Bank

Switching the 48K-byte section of memory is performed by two soft switches: `RAMRD` selects main or auxiliary memory for reading, and `RAMWRT` selects main or auxiliary memory for writing. As shown in Table 3-3, each switch has a pair of memory locations dedicated to it, one to select main memory, and the other to select auxiliary memory. Setting the read and write functions independently makes it possible for a program whose instructions are being fetched from one 48K-byte memory space to store data into the other 48K memory space.



Warning

Before using these switches, you must fully understand the effects of switching to auxiliary memory. For example, an application program running in the 48K bank of auxiliary memory that tries to use the built-in I/O routines by calling the standard I/O links will crash even though the main ROM, which contains the built-in I/O routines, has been selected. This happens because the standard links call DOS routines, and DOS is in the 48K bank of main memory, which is locked out while the application program is running in auxiliary memory.

When `RAMWRT` and `RAMRD` are on, auxiliary memory is used; when they are off, main memory is used.

Writing to the soft-switch at location `$C003` turns `RAMRD` on and enables auxiliary memory for reading; writing to location `$C002` turns `RAMRD` off and enables main memory for reading. Writing to the soft-switch at location `$C005` turns `RAMWRT` on and enables the auxiliary memory for writing; writing to location `$C004` turns `RAMWRT` off and enables main memory for writing. By setting these switches independently, you can use any of the four combinations of reading and writing in main or auxiliary memory.

Auxiliary memory corresponding to text Page 1 and high-resolution graphics Page 1 can be used as part of the 48K bank by using `RAMRD` and `RAMWRT`. These areas in auxiliary memory can also be controlled separately by using the display-page switches `80STORE`, `PAGE2`, and `HIRES` described in "Addressing the 80-Column Display Directly."

As shown in Table 3-3, the `80STORE` switch functions as an enabling switch: with it on, the `PAGE2` switch selects main memory or auxiliary memory. With the `HIRES` switch off, the `PAGE2` switch selects main or auxiliary memory in the text display Page 1, `$0400` to `$07FF`; with `HIRES` on, the `PAGE2` switch selects main or auxiliary memory in text Page 1 and high-resolution graphics Page 1, `$2000` to `$3FFF`.

If you are using both the 48K-bank control switches and the display-page control switches, the display-page control switches take priority: if `80STORE` is off, `RAMRD` and `RAMWRT` work for the entire memory space from `$0200` to `$BFFF`, but if `80STORE` is on, `RAMRD` and `RAMWRT` have no effect on the display page. Specifically, if `80STORE` is on and `HIRES` is off, `PAGE2` controls text Page 1 regardless of the settings of `RAMRD` and `RAMWRT`. Likewise, if `80STORE` and `HIRES` are both on, `PAGE2` controls both text Page 1 and high-resolution graphics Page 1, again regardless of `RAMRD` and `RAMWRT`.

You can find out the settings of these soft switches by reading from two other locations. The byte you read at location `$C013` has its high bit (the sign bit) set to 1 if `RAMRD` is on (auxiliary memory is enabled for reading), or 0 if `RAMRD` is off (the 48K block of main memory is enabled for reading). The byte at location `$C014` has its high bit set to 1 if `RAMWRT` is on (auxiliary memory is enabled for writing), or 0 if `RAMWRT` is off (the 48K block of main memory is enabled for writing).

Figure 3-2. Effect of Switching RAMRD and RAMWRT with 80STORE Off

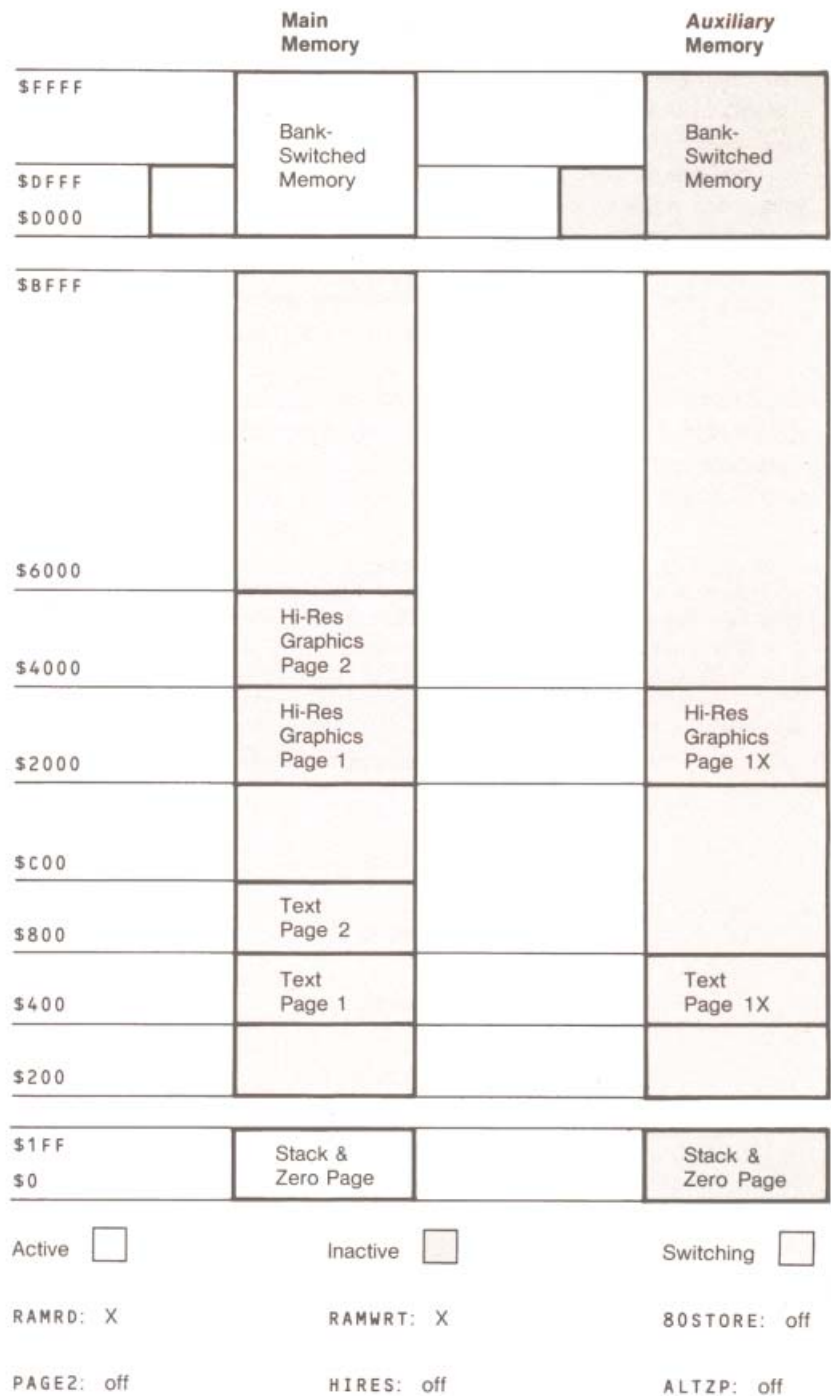

Figure 3-3. Effect of Switching RAMRD and RAMWRT with 80STORE and HIRES On

	Main Memory		Auxiliary Memory		
\$FFFF	Bank-Switched Memory		Bank-Switched Memory		
\$DFFF					
\$0000					
\$BFFF	Hi-Res Graphics Page 2		Hi-Res Graphics Page 1X		
\$6000					
\$4000					
\$2000		Hi-Res Graphics Page 1			
\$C00					
\$800		Text Page 2			
\$400		Text Page 1			
\$200					
\$1FF		Stack & Zero Page			Stack & Zero Page
\$0					

Active Inactive Switching
 RAMRD: X RAMWRT: X 80STORE: on
 PAGE2: off HIRES: on ALTZP: off

Switching High Memory, Stack, and Zero Page

The single soft switch ALTZP (alternate zero page) switches the bank-switched memory and the associated stack and zero page area between main and auxiliary memory. As shown in Table 3-3, writing to location \$C009 turns ALTZP on and selects auxiliary-memory stack and zero page; writing to the soft switch at location \$C008 turns ALTZP off and selects main-memory stack and zero page for reading and writing. The section "Auxiliary-Memory Subroutines" describes firmware that you can call to help you switch between main and auxiliary memory.

When the ALTZP soft switch is on, auxiliary memory is used; when it is off main memory is used.

To find out the setting of this soft switch, read location \$C016. The data byte you get has its high bit (the sign bit) set to 1 if ALTZP is on (the bank-switched area, stack, and zero page in the auxiliary memory are selected), or 0 if ALTZP is off (the same areas in main memory are selected).

To have enough memory locations for all of the soft switches and remain compatible with the Apple II and Apple II Plus, the soft switches listed in Table 3-3 share their memory locations with the keyboard functions listed in Chapter 2 of the *Apple IIe Reference Manual*. Whichever operation—read or write—is shown in Table 3-3 for controlling the auxiliary memory is the one that is **not** used for reading the keyboard and clearing the strobe.

Table 3-3. Auxiliary-Memory Select Switches. (1) When 80STORE is on, the PAGE2 switch works as shown; when 80STORE is off, PAGE2 doesn't affect the auxiliary memory. (2) When 80STORE is on, the HIRES switch enables you to use the PAGE2 switch to select between high-resolution Page 1 areas in main and auxiliary memory.

Name	Function	Location		Notes
		Hex	Decimal	
RAMRD	On: Read Aux. 48K	\$C003	49155 -16381	Write
	Off: Read Main 48K	\$C002	49154 -16382	Write
	Read RAMRD Switch	\$C013	49171 -16365	Read
RAMWRT	On: Write Aux. 48K	\$C005	49157 -16379	Write
	Off: Write Main 48K	\$C004	49156 -16380	Write
	Read RAMWRT Switch	\$C014	49172 -16354	Read
ALTZP	On: Aux. Stack, Zero Page, and Bank-Switched Memory	\$C009	49161 -16373	Write
	Off: Main Stack, Zero Page, and Bank-Switched Memory	\$C008	49160 -16374	Write
	Read ALTZP Switch	\$C016	49174 -16352	Read
80STORE	On: Access Page 1X	\$C001	49153 -16383	Write
	Off: Use RAMRD, RAMWRT	\$C000	49152 -16384	Write
	Read 80STORE Switch	\$C018	49176 -16360	Read
PAGE2	On: Access Aux. Memory	\$C055	49237 -16299	1
	Off: Access Main Memory	\$C054	49236 -16300	1
	Read PAGE2 Switch	\$C01C	49180 -16356	Read
HIRES	On: Access High-Resolution Page IX	\$C057	49239 -16297	2
	Off: Use RAMRD, RAMWRT	\$C056	49238 -16298	2
	Read HIRES Switch	\$C01D	49181 -16355	Read

Figure 3-4. Effect of Switching ALTZP

		Main Memory			Auxiliary Memory
\$FFFF		Bank-Switched Memory			Bank-Switched Memory
\$DFFF					
\$D000					
\$BFFF					
\$6000					
\$4000		Hi-Res Graphics Page 2			
\$2000		Hi-Res Graphics Page 1			Hi-Res Graphics Page 1X
\$C00					
\$800		Text Page 2			
\$400		Text Page 1			Text Page 1X
\$200					
\$1FF		Stack & Zero Page			Stack & Zero Page
\$0					

Active Inactive Switching
 RAMRD: off RAMWRT: off 80STORE: off
 PAGE2: off HIRES: off ALTZP: X

Figure 3-5. Effect of Switching PAGE2 with 80STORE and HIRES On

		Main Memory			Auxiliary Memory
\$FFFF		Bank-Switched Memory			Bank-Switched Memory
\$DFFF					
\$D000					
\$BFFF					
\$6000					
\$4000		Hi-Res Graphics Page 2			
\$2000		Hi-Res Graphics Page 1			Hi-Res Graphics Page 1X
\$C00					
\$800		Text Page 2			
\$400		Text Page 1			Text Page 1X
\$200					
\$1FF		Stack & Zero Page			Stack & Zero Page
\$0					

Active Inactive Switching

RAMRD: off RAMWRT: off 80STORE: on

PAGE2: X HIRES: on ALTZP: off

Auxiliary-Memory Subroutines

If you want to write assembly-language programs or procedures that use auxiliary memory, the built-in auxiliary-memory subroutines will be helpful. These subroutines make it possible to use the auxiliary memory without having to manipulate the soft switches already described.

The subroutines described in this section make it easier to use auxiliary memory, but they do not protect you from errors. You still have to plan your use of auxiliary memory to avoid inexplicable crashes.

You use these built-in subroutines the same way you use the I/O subroutines described in Chapter 3 of the *Apple IIe Reference Manual*: by making subroutine calls to their starting locations. Those locations are shown in Table 3-4.

Table 3-4. Auxiliary-Memory Routines

Subroutine Name	Location	Description
AUXMOVE	\$C311	Moves data blocks between main and auxiliary memory
XFER	\$C314	Transfers program control between main and auxiliary memory

Moving Data To Auxiliary Memory

In your assembly-language programs, you can use the built-in subroutine named `AUXMOVE` to copy blocks of data from main memory to auxiliary memory or from auxiliary memory to main memory. Before calling this routine, you must put the data addresses into byte pairs in page zero and set the carry bit to select the direction of the move—main to auxiliary or auxiliary to main.

The **carry bit** is bit 0 in the processor status word; use the `SEC` instruction to set it, and `CLC` to clear it.



Warning

Don't try to use `AUXMOVE` to copy data in page zero, page one (the 6502 stack), or in the bank-switched memory (`$D000-$FFFF`). `AUXMOVE` uses page zero while it is copying, so it can't handle moves in the memory space switched by `ALTZP`.

Remember that Pascal uses page zero too, so you can't use `AUXMOVE` from a Pascal procedure without saving the contents of page zero first, and restoring them afterward.

The pairs of bytes you use for passing addresses to this subroutine are called `A1`, `A2`, and `A4`; they are used for passing parameters to several of the Apple IIe's built-in routines. The addresses of these byte pairs are shown in Table 3-5.

Table 3-5. Parameters for `AUXMOVE` Routine

Name	Location	Parameter Passed
Carry		1 = Move from main to auxiliary memory 0 = Move from auxiliary to main memory
<code>A1L</code> <code>A1H</code>	<code>\$3C</code> <code>\$3D</code>	Source starting address, low-order byte Source starting address, high-order byte
<code>A2L</code> <code>A2H</code>	<code>\$3E</code> <code>\$3F</code>	Source ending address, low-order byte Source ending address, high-order byte
<code>A4L</code> <code>A4H</code>	<code>\$42</code> <code>\$43</code>	Destination starting address, low-order byte Destination starting address, high-order byte

Put the addresses of the first and last bytes of the block of memory you want to copy into `A1` and `A2`. Put the starting address of the block of memory you want to copy the data to into `A4`.

The `AUXMOVE` routine uses the carry bit to select the direction to copy the data. To copy data from main memory to auxiliary memory, set the carry bit (`SEC`); to copy data from auxiliary memory to main memory, clear the carry bit (`CLC`).

When you make the subroutine call to `AUXMOVE`, the subroutine copies the block of data as specified by the `A` registers and the carry bit. When it is finished, the accumulator and the `X` and `Y` registers are just as they were when you called it.

Transferring Control To Auxiliary Memory

You can use the built-in routine named `XFER` to transfer control to and from program segments in auxiliary memory. You must set up three parameters before using `XFER`: the address of the routine you are transferring to, the direction of the transfer (main to auxiliary or auxiliary to main), and which page zero and stack you want to use.

Table 3-6. Parameters for XFER Routine

Name or Location	Parameter Passed
Carry	1 = Transfer from main to auxiliary memory 0 = Transfer from auxiliary to main memory
Overflow	1 = Use page zero and stack in auxiliary memory 0 = Use page zero and stack in main memory
\$3E0	Program starting address, low-order byte
\$3EE	Program starting address, high-order byte

The **overflow bit** is bit 6 in the processor status word; use the `CLV` instruction to clear it. To set it, force an overflow by adding two numbers that total more than 127.



Put the transfer address into the two bytes at locations `$3E0` and `$3EE`, with the low-order byte first, as usual. The direction of the transfer is controlled by the carry bit: set the carry bit to transfer to a program in auxiliary memory; clear the carry bit to transfer to a program in main memory. Use the overflow bit to select which page zero and stack you want to use: clear the overflow bit to use the main memory; set the overflow bit to use the auxiliary memory.

Warning

It is the programmer's responsibility to save the current stack pointer somewhere in the current memory space before using `XFER` and to restore it after regaining control. Failure to do so will cause program errors.

After you have set up the parameters, pass control to the `XFER` routine by a jump instruction, rather than a subroutine call. `XFER` saves the accumulator and the transfer address on the current stack, then sets up the soft switches for the parameters you have selected and jumps to the new program.

Programming Examples

-
- 35 Identifying Different Configurations
 - 37 Apple IIe Identification in Assembly Language
 - 40 Apple IIe Identification from BASIC
 - 41 Apple IIe Identification from Pascal
 - 43 Storing Graphics Pages from Applesoft
 - 46 Storing Data Strings from Pascal



Programming Examples

This chapter contains examples showing how to use the auxiliary memory from a program. These examples are not intended to be universal routines that everyone can use as is; rather, they are representative examples showing how specific operations have been implemented. You will probably want to study the examples to see how it is done, then copy or modify them to suit your application.

Identifying Different Configurations

By identifying the configuration of the machine they are running on, application programs for the Apple IIe can take advantage of the new features and still remain compatible with older Apple II's. This section gives a procedure for doing this from assembly language and shows how to use the identification routine in programs written in Applesoft BASIC and Pascal.

The identification routine returns a value to the calling program that depends on the type of machine it is running on. Table 4-1 shows the return codes.

Table 4-1. Identification Return Codes

\$00	(0)	=	not an Apple IIe
\$20	(32)	=	Apple IIe, but no Apple IIe 80-Column Text Card
\$40	(64)	=	Apple IIe with 80-Column Text Card without auxiliary memory
\$80	(128)	=	Apple IIe with Extended 80-Column Text Card

Note: An 80-column card installed in expansion slot 3 will work in an Apple IIe the same as in an Apple II or Apple II Plus, but it does not activate the built-in 80-column firmware. The identification program does not detect such a card, but returns a code of 32: no Apple IIe 80-Column Text Card.

Here is an outline of the procedure the identification routine uses to identify an Apple IIe and its variations:

1. Save four identification bytes from the ROM/RAM area (\$D000 to \$FFFF).
2. Disable interrupts.
3. Switch bank-switched memory to read ROM by reading \$C089 twice.
4. Identify Apple IIe by finding the value 06 at \$FB83.
5. If Apple IIe, and high bit is on at location \$C017, then the computer has a text card.
6. If Apple IIe with 80-Column Text Card, then check for auxiliary memory:
 - a. If \$C013's high bit is on, then reading auxiliary memory so must have auxiliary memory.
 - b. If \$C016's high bit is on, then reading auxiliary zero page so must have auxiliary memory.
 - c. If sparse memory mapping (no upper four address bits so that \$800 has the same RAM location as \$C00), then no auxiliary memory.
 1. Exchange a section of zero page with the section of code that switches memory banks. This way the zero page data is saved and the program doesn't get switched out.
 2. Jump to the relocated code on page zero.
 3. Switch in auxiliary memory (\$200 - \$BFFF) for reading and writing by writing to \$C005 and \$C003.

Note: Auxiliary memory locations \$400-\$800 and \$2000-\$4000 may not be available depending upon the setting of soft switches for 80-column display and high-resolution graphics—they have priority over auxiliary memory selection.

4. Store a value at \$800, and see if same value at \$c00. If not, then auxiliary memory.
 5. Change value at \$c00, and see if \$800 changes to same value. If so, then no auxiliary memory.
 6. Set soft switches for reading and writing to main memory by writing to \$c002 and \$c004.
 7. Jump back into program on main RAM.
 8. Put zero page back.
7. Store identification byte for later reference by calling routine.
 8. If Pascal routine then turn card back on by reading \$c08B twice.
 9. The BASIC or assembly-language routines restore the RAM/ROM area as it originally was by checking four bytes saved at the start of the routine.
 10. Enable interrupts.
 11. Return to caller.

For some applications it may not be necessary to identify the exact configuration of the computer. For example, if your program cannot use the auxiliary memory, then you would not need to know whether it is available or not. In that case you may want to eliminate parts of the routine. For other applications the identification routine will use memory space required by your program, so you will need to move the routine to some other location.



Warning

If you change the identification routine, make sure that it still determines the configuration in the same way as the original. Later revisions of the Apple IIe may not support other identification procedures.

Apple IIe Identification in Assembly Language

The assembly-language subroutine given here is assembled to machine language in locations \$2D0 through \$3CF. To call the subroutine, your program does a jump to subroutine (JSR) to \$2D4. When the subroutine returns, the identification code is stored in memory location \$3CF.

Apple IIe Identification Program
1982

```

PARAM  ORG    $2D4
SAFE   EQU    $3CF
SAVE   EQU    $0001
        EQU    $2D0
        PHP
        SEI
        LDA    $E000
        STA    SAVE
        LDA    $D000
        STA    SAVE+1
        LDA    $D400
        STA    SAVE+2
        LDA    $D800
        STA    SAVE+3
        LDA    $C081
        LDA    $C081
        LDA    $FBB3
        CMP    #$6
        BNE    OUT1
        LDA    $C017
        BMI    OUT2
        LDA    $C013
        BMI    OUT4
        LDA    $C016
        BMI    OUT4
        LDY    #DONE-START
        LDX    START-1,Y
        LDA    SAFE-1,Y
        STX    SAFE-1,Y
        STA    START-1,Y
        DEY
        BNE    MV
        JMP    SAFE
ON      PHP
        LDY    #DONE-START
MV2     LDA    START-1,Y
        STA    SAFE-1,Y
        DEY
        BNE    MV2
        PLA
        BCS    OUT3
OUT4    LDA    #$80
        STA    PARAM
        JMP    OUT
OUT3    LDA    #$40
        STA    PARAM
        JMP    OUT
OUT2    LDA    #$20
        STA    PARAM
        JMP    OUT
OUT1    LDA    #0
        STA    PARAM

```

;START OF CODE RELOCATED ON PAGE ZERO
;START OF FOUR BYTE LANGUAGE CARD ID
;DISABLE INTERRUPTS

;SAVE 4 BYTES FROM
;ROMRAM AREA FOR LATER
;RESTORING OF RAMROM
;TO ORIGINAL CONDITION

;ENSURE READING ROM BY TURNING OFF
;BANKABLE MEM.
;GET APPLE IIE SIGNATURE BYTE

;IF NOT #6 THEN NOT APPLE IIE
;WAS 80 COLUMNS FOUND DURING STARTUP
;IF HI BIT ON THEN NO 80 COLUMN CARD
;SEE IF AUX MEMORY BEING READ
;AUX MEM BEING USED SO AUX MEM AVAIL.
;SEE IF AUX ZP BEING USED
;AUX ZP BEING USED SO AUX MEM AVAIL
;NOT SURE YET SO KEEP CHECKING
;SWAP SECTION OF ZP WITH
;CODE NEEDING SAFE LOCATION DURING
;READ AUX MEM

;JUMP TO SAFE GROUND
;BACK FROM SAFE GROUND. SAVE STATUS
;MOVE ZERO PAGE BACK

;GET BACK STATUS
;CARRY SET SO NO AUX MEM
;MADE IT SO THERE IS AUX MEM SET
;PARAM=\$80

;80 COLUMNS BUT NO AUX SO SET
;PARAM=\$40

;APPLE IIE BUT NO CARD SO SET
;PARAM=\$20

;NOT AN APPLE IIE SO SET PARAM=0

```

OUT      LDA      $E000      ;IF ALL 4 BYTES THE SAME
        CMP      SAVE      ;THE LANGUAGE CARD NEVER
        BNE     OUTON      ;WAS ON SO DO NOTHING
        LDA      $D000
        CMP     SAVE+1
        BNE     OUTON
        LDA      $D400
        CMP     SAVE+2
        BNE     OUTON
        LDA      $D800
        CMP     SAVE+3
        BEQ     GOOUT
OUTON    LDA      $C088      ;NO MATCH, SO TURN FIRST
        LDA      $E000      ;BANK OF LC ON AND CHECK
        CMP     SAVE
        BEQ     OUTON0
        LDA      $C080
        JMP     GOOUT
OUTON0   LDA      $D000
        CMP     SAVE+1      ;IF ALL LOCATIONS CHECK
        BEQ     OUTON1      ;THEN DO NOTHING MORE
        LDA      $C080      ;OTHERWISE TURN ON BANK 2
        JMP     GOOUT
OUTON1   LDA      $D400      ;CHECK SECOND BYTE IN BANK 1
        CMP     SAVE+2
        BEQ     OUTON2
        LDA      $C080      ;SELECT BANK 2
        JMP     GOOUT
OUTON2   LDA      $D800      ;CHECK THIRD BYTE IN BANK 1
        CMP     SAVE+3
        BEQ     GOOUT
        LDA      $C080      ;SELECT BANK 2
GOOUT    PLP      ;RESET INTERRUPTS
        RTS
*** ROUTINE RUN IN SAFE AREA NOT AFFECTED BY MOVES ***
START    LDA      #SEE      ;TRY STORING IN AUX MEM
        STA      $C005      ;WRITE TO AUX WHILE ON MAIN ZP
        STA      $C003      ;SET TO READ AUX RAM
        STA      $800       ;CHECK FOR SPARSE MEM MAPPING
        LDA      $C00       ;SEE IF SPARSE MEMORY -SAME VALUE
        CMP     #SEE      ;1K AWAY
        BNE     AUXMEM
        ASL     $C00       ;MAY BE SPARSE MEM SO CHANGE VALUE
        LDA      $800       ;& SEE WHAT HAPPENS
        CMP     $C00
        BNE     AUXMEM
        SEC      ;SPARSE MAPPING SO NO AUX MEM
        BCS     BACK
AUXMEM   CLC
BACK     STA      $C004      ;THERE IS AUX MEM
        STA      $C002      ;SWITCH BACK TO WRITE MAIN RAM
        JMP     ON         ;SWITCH BACK MAIN RAM READ
        ;CONTINUE PROGRAM ON PG 3 MAIN RAM
DONE     NOP              ;END OF RELOCATED PROGRAM MARKER

```

Apple IIe Identification from BASIC

One way to identify the configuration of an Apple IIe from BASIC is to load (using `BLOAD`) the machine-code version of the assembly-language routine described in the previous section, then execute a `CALL` statement to location 724 (`$2D4`). When the subroutine returns to the BASIC program, executing a `PEEK` at location 975 (`$3CF`) gets the result.

Here is another approach to writing a BASIC program to identify the type of Apple II it is running on. In this program the assembled code for the assembly-language identification routine from the last section is included in the `DATA` statements.

Apple IIe Identification from Applesoft BASIC

```
10 DATA 8, 120, 173, 0, 224, 141, 208, 2, 173, 0, 208, 141, 209, 2, 173, 0,
    212, 141, 210, 2, 173, 0, 216, 141, 211, 2, 173, 129, 192, 173, 129,
    192, 173, 179, 251, 201, 6, 208, 73, 173
20 DATA 23, 192, 48, 60, 173, 19, 192, 48, 39, 173, 22, 192, 48, 34, 160, 42,
    190, 162, 3, 185, 0, 0, 150, 0, 153, 162, 3, 136, 208, 242, 76, 1, 0,
    8, 160, 42, 185, 162, 3, 153
30 DATA 0, 0, 136, 208, 247, 104, 176, 8, 169, 128, 141, 207, 3, 76, 73, 3,
    169, 64, 141, 207, 3, 76, 73, 3, 169, 32, 141, 207, 3, 76, 73, 3, 169,
    0, 141, 207, 3, 173, 0, 224
40 DATA 205, 208, 2, 208, 24, 173, 0, 208, 205, 209, 2, 208, 16, 173, 0, 212,
    205, 210, 2, 208, 8, 173, 0, 216, 205, 211, 2, 240, 56, 173, 136, 192,
    173, 0, 224, 205, 208, 2, 240, 6
50 DATA 173, 128, 192, 76, 161, 3, 173, 0, 208, 205, 209, 2, 240, 6, 173, 128,
    192, 76, 161, 3, 173, 0, 212, 205, 210, 2, 240, 6, 173, 128, 192, 76,
    161, 3, 173, 0, 216, 205, 211, 2
60 DATA 240, 3, 173, 128, 192, 40, 96, 169, 238, 141, 5, 192, 141, 3, 192,
    141, 0, 8, 173, 0, 12, 201, 238, 208, 14, 14, 0, 12, 173, 0, 8, 205, 0,
    12, 208, 3, 56, 176, 1, 24
70 DATA 141, 4, 192, 141, 2, 192, 76, 29, 3, 234
80 ALOOK = 975:START = 724
90 FOR I = 0 TO 249
100 READ BYTE
110 POKE START + I, BYTE
120 NEXT
130 CALL START
140 RESULTS = PEEK (ALOOK)
150 PRINT RESULTS: REM RESULTS OF 0 MEAN NOT A IIE; 32 MEANS AIIE BUT NO 80
    COLUMNS; 64 MEANS AIIE WITH 80 COLUMNS BUT NO AUX MEM; 128 MEANS AIIE
    WITH AUX MEM
160 END
```

Apple IIe Identification from Pascal

Here is the assembly-language identification program previously described in the form of a Pascal procedure.

Apple IIe Identification from Pascal

```
;
    .MACRO    POP          ;SAVE PASCAL RETURN ADDRESS
    PLA
    STA      %1
    PLA
    STA      %1+1
    .ENDM

;
;-----
;
    .MACRO    PULL_BIAS   ;ADJUST FOR FUNCTION
    PLA
    PLA
    PLA
    PLA
    .ENDM

;
;-----
;
    .FUNC     ID,0
RETURN .EQU    0          ;TEMP STORAGE OF RETURN TO PASCAL ADDRESS
SAFE   .EQU    0002      ;START OF CODE RELOCATED ON PAGE ZERO
;
;-----
;
    POP      RETURN
    PULL_BIAS
    PHP                      ;LOCK OUT INTERRUPTS
    SEI
    LDA      0C089           ;ENSURE READING ROM BY TURNING OFF
    LDA      0C089           ;BANKABLE MEM
    LDA      0F883           ;GET APPLE IIe SIGNITURE BYTE
    CMP      #6
    BNE     OUT1             ;IF NOT #6 THEN NOT APPLE IIe
    LDA      0C017           ;WAS 80 COLUMNS FOUND DURING STARTUP
    BMI     OUT2             ;IF HIGH BIT ON THEN NO 80-COLUMN CARD
    LDA      0C013           ;SEE IF AUX MEMORY BEING READ
    BMI     OUT4             ;AUX MEM BEING USED SO AUX MEM AVAIL
    LDA      0C016           ;SEE IF AUX ZP BEING USED
    BMI     OUT4             ;AUX ZP BEING USED SO AUX MEM AVAIL
    LDY     #2A              ;NOT SURE YET SO KEEP CHECKING
MV     LDX     START-1,Y    ;SWAP SECTION OF ZP WITH
    LDA     SAFE-1,Y        ;CODE NEEDING SAFE LOCATION DURING
    STX     SAFE-1,Y        ;READ AUX MEM
    STA     START-1,Y
    DEY
```

```

        BNE      MV
        JMP      SAFE      ; JUMP TO SAFE GROUND
ON      PHP      ; BACK FROM SAFE GROUND. SAVE STATUS
        LDY      #2A      ; MOVE ZERO PAGE BACK
MV2     LDA      START-1,Y
        STA      SAFE-1,Y
        DEY
        BNE      MV2
        PLA      ; GET BACK STATUS
        BCS      OUT3     ; CARRY SET SO NO AUX MEM
OUT4    LDA      #80      ; MADE IT SO THERE IS AUX MEM-SET
        STA      PARAM    ; PARAM=$80
        JMP      OUT
OUT3    LDA      #40      ; 80 COLUMNS BUT NO AUX SO SET
        STA      PARAM    ; PARAM=$40
        JMP      OUT
OUT2    LDA      #20      ; APPLE IIe BUT NO CARD SO SET
        STA      PARAM    ; PARAM=$20
        JMP      OUT
OUT1    LDA      #0       ; NOT AN APPLE IIe SO SET PARAM=0
        STA      PARAM
OUT     LDA      0C08B    ; GET PASCAL BACK
        LDA      0C08B
        PLP      ; REACTIVATE INTERRUPTS
        LDA      #0       ; PUT 0 IN HIGH BYTE OF RESULTS
        PHA
        LDA      PARAM    ; PUT FOUND VALUE IN LOW BYTE & PUSH
        PHA
        LDA      RETURN+1 ; RESTORE PASCAL RETURN ADD
        PHA
        LDA      RETURN
        PHA
        RTS
PARAM   .BYTE
;
; ROUTINE RUN IN SAFE AREA NOT AFFECTED BY MOVES
;
START   LDA      #0EE     ; TRY STORING . IN AUX MEM
        STA      0C005    ; WRITE TO AUX WHILE ON MAIN ZP
        STA      0C003    ; SET TO READ AUX RAM
        STA      0800     ; CHECK FOR SPARSE MEM MAPPING
        LDA      0C00     ; SEE IF SPARSE MEMORY-SAME VALUE
        CMP      #0EE     ; 1K AWAY
        BNE      AUXMEM
        ASL      0C00     ; MAY BE SPARSE MEM SO CHANGE VALUE
        LDA      0800     ; & SEE WHAT HAPPENS
        CMP      0C00
        BNE      AUXMEM
        SEC      ; SPARSE MAPPING SO NO AUX MEM
        BCS      BACK
AUXMEM  CLC      ; THERE IS AUX MEM
BACK    STA      0C004    ; SWITCH BACK TO WRITE MAIN RAM
        STA      0C002    ; SWITCH BACK MAIN RAM READ
        JMP      ON      ; CONTINUE PROGRAM ON PG 3 MAIN RAM
DONE    NOP      ; END OF RELOCATED PROGRAM MARKER
        .END

```

Storing Graphics Pages from Applesoft

It is generally not practical to use the auxiliary memory from BASIC. A BASIC program can only move its variables in memory by getting very tricky with PEEK and POKE commands, an approach that is both inefficient and dangerous.

There is one form of data that uses lots of memory and is simple enough to handle from Applesoft: high-resolution graphics pages. The auxiliary memory is an ideal place to store as many as five complex graphics pages for rapid loading into the display buffer.

Like all of these examples, the following Applesoft example includes two short assembly-language subroutines. The first listing is the assembly-language form of the subroutines. The second listing is the Applesoft program with the machine-language subroutine included as a series of DATA statements. This method of adding a machine-language subroutine to a BASIC program is not very efficient, but it is convenient for short subroutines.

The program has two phases: in the first, the program generates five different high-resolution views and stores them in auxiliary memory; in the second, the program loads the stored graphics pages back into main memory one after another.

Hi-Res Page Mover for Auxiliary Memory Demo. Using AUXMOVE Subroutine. July 1982

PARAM = Hi byte of BUF. ADDR. (Page # times 32).

Call PUTPAGE to copy hi-res graphics page to AUX. MEM. location specified by PARAM.

Call GETPAGE to load hi-res graphics page from AUX. MEM. location specified by PARAM.

```

                                DSECT
                                ORG      $300
SRCBEG      DS      2
SRCEND      DS      2
            DS      2
DESBEG      DS      2
            DEND

*
PG1BEG      EQU      $2000
PG1END      EQU      $3FFB
AUXMOVE     EQU      $C311
*

                                ORG      $300
PARAM       DS      1
*
* MOVE HI-RES PAGE TO AUX MEM:
*
```



```

PUTPAG      EQU      *
            LDA      #)PG1BEG      ;PAGE STARTING
            STA      SRCBEG        ;ADDRESS
            LDA      #(<PG1BEG
            STA      SRCBEG+1

*
            LDA      #)PG1END      ;PAGE ENDING
            STA      SRCEND        ;ADDRESS
            LDA      #(<PG1END
            STA      SRCEND+1

*
* PARM → DESTINATION ADDRESS
*
            LDA      #0            ;DESTINATION
            STA      DESTBEG       ;PAGE BEGINNING
            LDA      PARM          ;ADDRESS
            STA      DESTBEG+1

*
* USE AUXMOVE TO DO IT:
*
            SEC
            JSR      AUXMOVE
            RTS

*
* COPY PAGE TO MAIN MEMORY
*
GETPAG      EQU      *
            LDA      #)PG1BEG      ;DESTINATION
            STA      DESTBEG       ;PAGE BEGINNING
            LDA      #(<PG1BEG
            STA      DESTBEG+1

*
* PARM → SOURCE ADDRESSES
*
            LDA      #0            ;PARM FOR
            STA      SRCBEG        ;SOURCE BEGINNING
            LDA      PARM          ;ADDRESS
            STA      SRCBEG+1

*
            LDA      #)PF8        ;COMPUTE SOURCE
            STA      SRCEND        ;ENDING ADDRESS
            CLC
            LDA      PARM
            ADC      #)PF8
            STA      SRCEND+1

*
* USE AUXMOVE TO DO IT:
*
            CLC
            JSR      AUXMOVE
            RTS

```

Globe. Hi-res graphics demonstration for the Apple IIe Extended 80-Column Text Card.

```

99  REM   This program draws five views of a rotating globe and stores
100 REM   five copies of the Hi-Res page in auxiliary memory. It then
107 REM   moves the views from auxiliary memory back into the Hi-Res
108 REM   graphics page in main memory, one after another. The rapid
109 REM   succession of views creates the impression of a solid
117 REM   rotating globe.
118 REM
119 REM
127 REM
128 REM
129 REM
150 REM
160 TEST : HOME
170 PRINT CHR$(17): REM CTRL-Q for 40-column display
198 REM
199 REM   Pager subroutines in machine language:
200 DATA 169,0,133,60,169,32,133,61,169,248,133,62,169,63,133
210 DATA 63,169,0,133,66,173,0,3,133,67,56,32,17,195,96,0
220 DATA 169,0,133,66,169,32,133,67,169,0,133,60,173,0,3,133
230 DATA 61,169,248,133,62,24,173,0,3,105,31,133,63,24,32,17,195
    ,96

298 REM
299 REM   Read the Pager subroutines and store at $301:
300 PARM = 768:PUTPAGE = 769:BRINGPAGE = 800
310 FOR I = 0 TO 64
320   : READ BYTE
330   : POKE PUTPAGE + I, BYTE
340 NEXT I
998 REM
999 REM   Set up constants for drawing meridians (ellipses):
1000 PI = 3.14159265:P2 = PI / 2
1010 SP = P2 / 9: REM angle between meridians
1020 EP = SP / 5: REM starting angle increment between views
1030 DT = PI / 15: REM segment size (angle) for drawing meridians
1040 B = 1: REM Semi-major axis of ellipses.
1998 REM
1999 REM   Loop starting at 2000 draws five views and stores them:
2000 FOR VIEW = 1 TO 5
2029   : REM HGR to erase previous view:
2030   : HGR : HCOLOR= 3
2040   : REM Draw picture frame:
2050   : HPLOT 60,0 TO 60,159 TO 219,159 TO 219,0 TO 60,0
2100   : VTAB 23: HTAB 9
2120   : PRINT "...constructing view #";VIEW
2988   : REM
2990   : DP = EP * VIEW: REM different starting angle each view.
2999   : REM Loop starting at 3000 draws meridians (ellipses):
3000   : FOR IANGLE = DP TO PI STEP SP
3100   :: A = COS (IANGLE): REM Semi-minor axis of ellipse.
3200   :: FIRST = 1: REM for plotting
3990   :: REM
3999   :: REM Loop starting at 4000 draws a meridian (ellipse):
4000   :: FOR THETA = 0 TO PI STEP DT
4020   ::: LET X = A * SIN (THETA)
4040   ::: LET Y = B * COS (THETA)
4059   ::: REM Next two lines scale PX and PY for plotting.
4060   ::: LET PX = X * 55 + 140
4080   ::: LET PY = Y * 55 + 80
4100   ::: IF FIRST THEN HPLOT PX,PY:FIRST = 0

```

```

4110 ::: IF NOT FIRST THEN H PLOT TO PX,PY
4200 ::: NEXT THETA
4300 : NEXT IANGLE
4400 : VTAB 23: HTAB 9
4410 : PRINT "...storing view #";VIEW
4499 : REM
4500 : REM Put view in auxiliary memory:
4510 : POKE PARM,VIEW * 32
4520 : CALL PUTPAGE
4600 NEXT VIEW
4689 REM
4690 REM   Five views stored-- now show them:
4700 HOME : VTAB 23
4720 HTAB 3: PRINT "Loading views from auxiliary memory."
4998 REM
4999 REM   Loop starting at 5000 brings views from auxiliary memory:
5000 FOR VIEW = 1 TO 5
5020 : POKE PARM,VIEW * 32
5040 : CALL BRINGPAGE
5060 NEXT VIEW
5997 REM
5998 REM   Repeat same five views forever,
5999 REM   or until the fuse blows:
6000 GOTO 5000

```

Storing Data Strings from Pascal

These Pascal routines use locations \$C00 to \$BFFF in the auxiliary memory for storage and retrieval of strings.

The code that moves the strings to and from auxiliary memory is stored at E000 in the Extended 80-Column Text Card. A separate initialization routine puts this code at E000, just once, to maintain system performance.

The retrieval routine is very fast, roughly equivalent to a `MoveLeft` from a `Packed Array of Char`. The storage routine is less efficient; if speed is important in your program, you may want to try to optimize it.

Like the other examples, these routines were written for a particular application and are not general-purpose subroutines. They are included here to show you the kind of thing you can do with the auxiliary memory.

Auxiliary Memory String Routines
by R. Lissner

The following routine is performed only once. The routines that move strings in and out of the Extended 80-Column Text Card are moved to Exxx in the auxiliary memory.

```

;
;
; .TITLE "ASSEMBLY ROUTINES IIE INITIALIZATION"
; .PAGE
; .NOMACROLIST
; .NOPATCHLIST
;
RDMAIN48 .EQU      0C002      ; SOFT SWITCHES. SEE
RDAUX48  .EQU      0C003      ; IIE REFERENCE MANUAL
WRMAIN48 .EQU      0C004
WRAUX48  .EQU      0C005
RWMAIN16 .EQU      0C008
RWAUX16  .EQU      0C009
HIRESOFF .EQU      0C056
;
;
RETURN0  .EQU      028
RETURN1  .EQU      02A
;
; REGISTER MAP
;
ZREG00   .EQU      0
ZREG02   .EQU      4
ZREG04   .EQU      6
;
OUT4     STA        RWAUX16    ; WRITE AUX MEMORY
        LDY        #80        ; LENGTH OF PATCH
OUT4ME0  LDA        E002STUF-1,Y
        STA        0E001,Y
        DEY
        BNE        OUT4ME0
        LDY        #0FF       ; LENGTH OF PATCH
OUT4ME1  LDA        E102STUF-1,Y ; CODE NEEDING SAFE LOCATION
        STA        0E101,Y
        DEY
        BNE        OUT4ME1
        STA        RWMAIN16   ; WRITE MAIN MEMORY
        STA        HIRESOFF   ; MAKE HIRES P. AVAILABLE
; END OF THIS ROUTINE
;
;
; Purpose: Moves a string from auxiliary memory to Pascal.
;
; If the program finds the Extended 80-Column Text Card, the
; following code is moved to E002.
;
;
; The program gets here from a JSR in MOVE_FR_AUX, and goes back so
; that the auxiliary memory can be turned back off. Zero page on the
; extended text card contains ZREG00 and ZREG02; they are the
; arguments for the move. Stack usage: The return address in 48K main
; memory is stored in the auxiliary stack. This is the only use of the
; auxiliary memory stack.

```



```

;
;
E002STUF  CLD
           STA      RDAUX48      ; READ AUX 48K
           LDY      #0
           LDA      (ZREG00),Y   ; READING AUX 48K
;
           USING AUX ZERO PAGE
           STA      (ZREG02),Y   ; WRITING MAIN 48K
           BEQ      E002EXIT     ; NOT LIKELY, BUT POSSIBLE
           TAY
E002LOOP  LDA      (ZREG00),Y
           STA      (ZREG02),Y
           DEY
           BNE      E002LOOP
E002EXIT  STA      RDMAIN48      ; READ MAIN 48K
           RTS          ; GOING BACK TO 48K RAM
;
;
;

```

Purpose: Moves a string from Pascal to auxiliary memory.

If the program finds the Extended 80-Column Text Card, the following code is moved to E102.

The program gets here from a JSR in MOVE_TO_AUX, and goes back so that the auxiliary memory can be turned back off. Zero page on the extended text card contains ZREG00 and ZREG02 exactly as they are found on the main zero page.

Stack usage: The return address in 48K main memory is stored in the auxiliary stack. This is the only use of the auxiliary memory stack.

Note also that the auxiliary zero page is used for the to and from addresses.

ZREG00: Address of string that wants to be stored
ZREG02: Address of integer that wants to know where it was stored, or receive x'0000' if no room
ZREG04: Used to index on receiving address

```

;
NEXTAVAI  .EQU      0E102
E102STUF  .WORD     0C00
           CLD
; X'FF' MEANS RESET BACK TO BEGINNING. DONE FOR EACH NEW FILE
           LDY      #0
           LDA      (ZREG00),Y
           CMP      #0FF
           BNE      E102C0
           LDA      #0          ; RESET TO $C00
           STA      NEXTAVAI+1
           LDA      #0
           STA      NEXTAVAI
           BEQ      E102FAIL    ; UNCONDITIONAL
;
           CONTINUE WITH NORMAL ROUTINES
E102C0    LDA      NEXTAVAI+1
           CMP      #0BF        ; CHECK FOR FULL
           BNE      E102C1

```

```

; SPACE IS FULL, SO RETURN ZERO
LDA      #0
TAY
STA      (ZREG02),Y      ; RETURN A ZERO, FULL
INY
STA      (ZREG02),Y
BNE      E102FAIL      ; UNCONDITIONAL
; THERE IS STILL ROOM, SO CONTINUE
E102C1   LDY      #1
STA      (ZREG02),Y      ; STORE IN RETURN ADDR
STA      ZREG04+1      ; SETUP THE MOVE
DEY
LDA      NEXTAVAI
STA      (ZREG02),Y      ; LOW BYTE OF RETURN
STA      ZREG04      ; MORE OF THE MOVE
; NOW INCREMENT THE NEXT AVAILABLE ADDRESS
CLC
ADC      #1      ; ADD 1 FOR STRING LENGTH
BNE      *+5
INC      NEXTAVAI+1      ; ROLLED INTO NEXT PAGE
CLC
LDY      #0
ADC      (ZREG00),Y      ; ADD LENGTH OF STRING
STA      NEXTAVAI      ; PUT IT BACK
BCC      *+5
INC      NEXTAVAI+1      ; INTO NEXT PAGE
STA      WRAUX48      ; WRITING INTO AUX 48K
LDA      (ZREG00),Y      ; READING AUX 48K
USING AUX ZERO PAGE
STA      (ZREG04),Y      ; WRITING MAIN 48K
BEQ      E102EXIT
TAY
E102LOOP LDA      (ZREG00),Y
STA      (ZREG04),Y
DEY
BNE      E102LOOP
E102EXIT STA      WRMAIN48      ; NOW WRITE MAIN MEM
E102FAIL RTS      ; GOING BACK TO 48K RAM
.END

;
; The following code is linked into the main Pascal program. This code
; stores the arguments in the auxiliary zero page and then jumps to Exxx on
; the Extended 80-Column Text Card.
;
.TITLE "ASSEMBLY ROUTINES FOR IIE"
.PAGE
.NOMACROLIST
.NOPATCHLIST
;
RDMAIN48 .EQU      0C002
RDAUX48 .EQU      0C003
WRMAIN48 .EQU      0C004
WRAUX48 .EQU      0C005
RWAUX16 .EQU      0C009
RWMAIN16 .EQU      0C008
;
; RETURN ADDRESS ZERO PAGE LOCATIONS
;
RETURN0 .EQU      028
RETURN1 .EQU      02A
;

```

```

; REGISTER MAP
;
ZREG00 .EQU 0
ZREG02 .EQU 4
;
;
; .TITLE "MOVE STRINGS FROM IIE AUXILIARY MEMORY"
; .PROC MOVEFRAU,2
;
;
; PROCEDURE MOVE_FR_AUX (FROMA; VAR TOA) (* Move string *)
;
; Purpose: Move a string from auxiliary memory to Pascal. Most of the
; actual move is done at auxiliary memory location E002.
;
; Stack usage: Input, output addresses.
;
;
; STORE RETURN ADDR IN AUX ZERO PAGE
POP RETURN0 ; RETURN TO PASCAL
; ADDRESSES ARE TWO BYTES. PULL BOTH BYTES OFF THE MAIN STACK, THEN SWITCH
; TO AUX ZERO PAGE AND STORE BOTH BYTES.
PLA
TAX
PLA
STA RWAUX16 ; SWITCH TO AUX ZP
STX ZREG02 ; IN AUX ZERO PAGE
STA ZREG02+1 ; STILL IN AUX MEM
STA RWMAIN16 ; SWITCH TO MAIN ZP
; STORE FROM ADDRESS IN AUX ZERO PAGE
PLA
TAX
PLA
STA RWAUX16 ; SWITCH TO AUX ZP
STX ZREG00 ; IN AUX ZERO PAGE
STA ZREG00+1 ; STILL IN AUX MEM
; NOW GET OVER TO AUX PAGE AND DO IT ALL
JSR 0E002
; NOW PROCESS COMING BACK FROM E002 IN AUX MEMORY
STA RWMAIN16 ; MAIN ZP AND TOP
PUSH RETURN0
RTS ; BACK TO PASCAL
;
;
; .TITLE "MOVE STRINGS TO IIE AUXILIARY MEMORY"
; .PROC MoveToAu,2
;
; PROCEDURE MOVE_TO_AUX (VAR FROMA; VAR TOA) (* Move string *)
;
; Purpose: Move a Pascal string to auxiliary memory. Most of the
; actual move is done at auxiliary memory location E102.
;
; Stack usage: Input, output addresses.
;
;
; STORE RETURN ADDR IN AUX ZERO PAGE
POP RETURN0 ; MAIN ZP STACK

```

```

; NOW STORE TO ADDRESS IN AUX ZERO PAGE
PLA
TAX
PLA
STA      RWAUX16
STX      ZREG02
STA      ZREG02+1
STA      RWMAIN16
; STORE FROM ADDRESS IN AUX ZERO PAGE
PLA
TAX
PLA
STA      RWAUX16
STX      ZREG00
STA      ZREG00+1
; NOW GET OVER TO AUX PAGE AND DO IT ALL
JSR      0E104
; RETURN FROM E104 IN AUX MEMORY
STA      RWMAIN16
PUSH     RETURN0
RTS
;
      .END

```

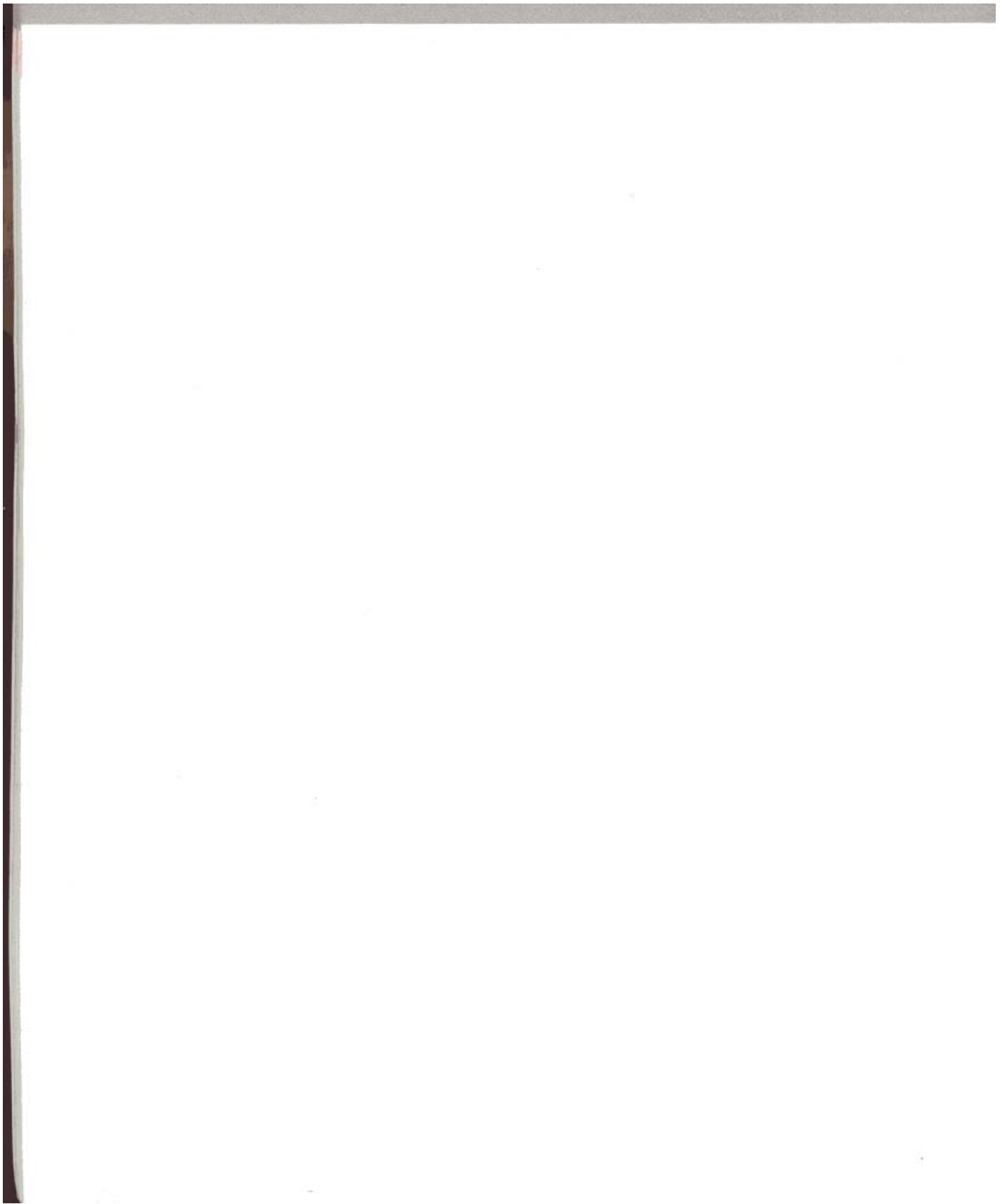
Index

A

- accumulator 30, 31
- address bus 7
- address 30
 - data 29
 - destination starting 30
 - program starting 31
 - source starting 30
 - source ending 30
 - transfer 31
- alternate zero page 25
- ALTZP soft switch 25
 - figure 27
 - table 26
 - warning 29
- Annunciator 3 11
 - display page used 12
- Apple II 35, 36
 - compatibility 25
 - system software 15
- Apple II Plus 35, 36
 - compatibility 25
- Apple IIe viii, 7, 35
 - control keys 4
 - display memory 18
 - display modes 4
 - display pages 16
 - double high-resolution graphics 11-12
 - escape sequences 4
 - identification from assembly language 37
 - identification from BASIC 40
 - identification from Pascal 41
 - installing card in 3
 - processor 4
 - Rev A 12
 - Rev B 11
- Apple IIe Identification Program 38-39
- Apple IIe Identification Program (Pascal) 41-42
- Applesoft BASIC 17, 35
 - program example using AUXMOVE 44
 - using to store graphics pages 43
- application programs viii, 21, 35
 - running with the card vii
- assembly language 35, 37
 - subroutines 15, 37, 43
 - programs to use auxiliary memory 29
 - routine for Pascal 41
- AUX. CONNECTOR 3
 - See also auxiliary slot
- auxiliary memory viii, 4, 7, 9, 10, 11, 12, 15, 16, 18, 19, 21, 22, 25, 29, 31, 36, 37
 - accessing 4
 - address bus 9
 - addressing 7
 - amount 3
 - careless switching 4
 - how it works 7-12
 - select switches, table 26
 - subroutines 29-31
 - switching to from bank-switched memory 9
 - transferring control to 30-31
 - using viii
 - using from a program, examples, 35-51
 - warning 9, 15
- Auxiliary Memory String Routines 47-51
- auxiliary RAM 15
- auxiliary slot 11
 - AUX. CONNECTOR 3
- AUXMOVE subroutine 15, 29, 30
 - example using (Applesoft) 44
 - parameters 30
 - warning 29

B

- bandwidth, video monitor 11
- bank switches 9
- bank-switched memory 9, 25, 36
 - warning 9
 - with auxiliary memory 9
- BASIC 15, 37, 40, 43
 - Applesoft 17
 - Integer 17
 - reading soft switches from 17
 - warning using 15
- bit 0 29
- bit 7 17
- bit
 - carry 29, 31
 - color-select 19
 - high-order 19, 22, 25
 - overflow 31
 - sign 17, 22, 25
- built-in 80-column display routines 16
- built-in I/O routines 21
- built-in subroutines 29, 30
- bus
 - address 7
 - data 7
- byte
 - high-order 30, 31
 - low-order 30, 31

C

- CALL statement 15, 40
- carry bit 29, 30, 31
- circuitry, display 18
- CLC instruction 29, 30
- clock cycle 9
 - with 80-column display on 10
- CLV instruction 31
- color monitor, RGB 10, 11
- color-select bit 19
- commands
 - PEEK 17, 43
 - POKE 17, 43
- computer configuration, identifying 35-37
- configuration 35
- configuration of the computer 35-37
- control keys 4
- control switches 22

D

- data addresses 29
- data bus 7, 11
- data, moving 29
- DATA statements 40, 43
- data strings 46
- decimal 17
- destination starting address 30
- display buffer 43
- display circuitry 18
- display cycle 9
- display data 10, 21
- display modes 4
- display pages 16
 - control switches 22
 - length 9
 - locations, table 16
 - See also graphics pages
- display soft switches, table 18
- display, 80-column 19
 - figure 20
- DOS 3.3 viii, 15, 21
- dot patterns 10
- double high-resolution graphics (560 dot) 11-12, 19
 - obtaining 11
 - board necessary for 12
 - with Rev A Apple IIe 12

E

- 80-column card, any 36
- 80-column display 10, 11, 16, 19, 36
 - addressing directly 18
 - bandwidth needed 10
 - firmware 3, 4, 36
 - figure 20
 - map 10
 - storing data 9
 - switch for 11
 - with clock cycles 9
 - versus 40-column display (dot patterns) 10
- 80COL soft switch 18
- 80-Column Text Card 4, 16, 35, 36
- 80-column text 11, 12, 19
 - mode 12
- 80STORE soft switch 18, 19, 22
 - figure 23, 24, 28
 - table 26
 - warning 21

escape sequences 4
expansion slot 3 36
Extended 80-Column Text
Card 11, 35, 46
buffer 10
connecting pins 11
differences from 80-Column
Text Card viii
storing data directly 19

F

firmware, 80-column display 3,
4, 36
560-dot graphics 11, 12, 16
See also 280-dot graphics
40-column text 11
mode 16
48K bank, switching 21-22
48K memory space 9, 21
14MHz 10, 11
functions
keyboard 17, 25
Pascal 15

G

Globe 45-46
graphics mode, double high-
resolution 12, 19
graphics Page 1X (high-
resolution) 19
graphics pages 43
storing from Applesoft 43
See also display pages
graphics
280-dot 16
560-dot 12, 16
double-high-resolution 19
double-high-resolution
memory mapping 19
high-resolution, Page 1 19,
22
high-resolution, Page 1X 19
high-resolution program
example 45-46

H

hexadecimal 16, 17
high-level languages 15
high-order bit 17, 19, 22, 25
high-order byte 30, 31
high-resolution graphics 11,
36, 43
Page 1 12, 19, 22
Page 1X 19

pages 43
program example 45-46
switch for 11
HIRES soft switch 18, 19, 22
figure 24, 28
table 26
warning 21
horizontal resolution 11

I

identification return codes,
table 35
identification routine 35, 40
outline 36-37
warning 37
identification, Apple IIe
(assembly language) 37
identification, Apple IIe from
BASIC 40
installation 3
instruction
CLC 29, 30
CLV 31
JSR 37
jump 31
SEC 29, 30
Integer BASIC 17
interpreter, warning using 15
interrupts 36, 37
I/O 7
links, standard 21
routines, built-in 21
subroutines 29

J

JSR instruction 37
jump instruction 31
jump to subroutine (JSR) 37

K

keyboard functions 17, 25

L

low bandwidth monitor 19
low-order byte 30, 31
low-resolution graphics 11, 16

M

machine language 17
programs 17
main logic board
buffer 10
Rev A 12
Rev B 11

main memory viii, 7, 9, 10, 12, 15, 16, 18, 19, 21, 25, 31
 address bus 9
 switching 4

memory
 amount card contains viii
 auxiliary 15
 select switches, table 26
 bank-switched 25
 reading 21, 25
 writing 21, 22, 25

memory locations 17

Memory Management Unit 7
 diagram 8

memory pages, length 9

memory switching 15

mixed graphics modes 11

MIXED soft switch 18

MMU 7

modes, mixed graphics 11

Molex-type pins 11

Monitor program 19

monitor, low bandwidth 19

monochrome monitor 11

moving data 29

N

negative decimal 17

O

operation
 read 17, 25
 warning with 17
 write 17, 25
 warning with 17

overflow bit 31

P

Page 1
 display 19
 graphics 22
 high-resolution graphics 12, 19
 text 16, 18, 22

page one 9
 warning 29

Page 1X
 display 16, 18, 19
 high-resolution graphics 19
 text 16

pages, high-resolution
 graphics 43

Page 2, text 16

PAGE2 soft switch 18, 19, 22
 figure 28
 table 26
 warning 21

page zero 9, 29, 30, 31
 warning 29

parameters 30

Pascal 30, 35, 37, 41
 1.1 viii, 15
 functions 15
 procedures 15, 30
 routines, programming
 examples 47-51
 storing data strings from 46
 warning using 15

PEEK 17, 40, 43

POKE 43, 17

power-on light 3

procedures, Pascal 15, 30

procedures, assembly-
 language 29

processor 4

processor status word 29, 31

program starting address 31

program
 Apple IIe identification 38-39
 Apple IIe identification
 (Pascal) 41-42
 Applesoft example using
 AUXMOVE 44
 assembly-language 29
 machine-language 17
 Monitor 19

programmable memory,
 amount 4

programming examples 35-51

R

RAM 4, 7
 amount 3
 auxiliary memory 15

RAMRD soft switch 21, 22
 figure 23, 24
 table 26

RAMWRT soft switch 21, 22
 figure 23, 24
 table 26

read operation 17, 25
 warning 17

reading memory 21, 25

registers, X and Y 30

Rev A Apple IIe 12

Rev A main logic board,
 warning 12

Rev B main logic board 11

RGB color monitor 10, 11

ROM 7, 21
 routine, identification 35, 40
 outline 36-37
 routines, built-in 30
S
 SEC instruction 29, 30
 7MHz 10
 sign bit 17, 22, 25
 6502 microprocessor 7
 6502 stack 9
 warning 29
 slot 3 36
 soft switches 7, 11, 15, 16, 17,
 29, 31, 37
 accommodating 25
 ALTZP 25
 figure 27
 table 26
 warning 29
 Annunciator 3 11
 80COL 18
 80STORE 18, 19, 22
 warning 21
 figure 23, 24, 28
 table 26
 HIRES 18, 19, 22
 warning 21
 figure 24, 28
 table 26
 MIXED 18
 PAGE2 18, 19, 22
 figure 28
 table 26
 warning 21
 RAMRD 21, 22
 figure 23, 24
 table 26
 RAMWRT 21, 22
 figure 23, 24
 table 26
 setting 15-31
 TEXT 18
 warning 17, 21
 software, Apple II system 15
 source ending address 30
 source starting address 30
 sparse memory mapping 36
 stack 25, 31
 warning when switching 15
 stack pointer, warning 31
 standard I/O links 21
 string routines, Pascal
 examples 47-51
 subroutine call 31

subroutines
 assembly-language 15, 37,
 43
 auxiliary-memory 15, 29-31
 AUXMOVE 15, 29, 30
 parameters 30
 warning 29
 built-in 29
 I/O 29
 XFER 15, 29
 parameters 31
 warning 31
 switch locations 17, 21
 decimal 17
 hexadecimal 17
 negative decimal 17
 switches, control
 48K bank 22
 display-page 22
 system software for the
 Apple II 15
T
 television set 10, 19
 text display, 80-column 12, 19
 figure 20
 text Page 1 9, 16, 18, 22
 text Page 1X 16
 text Page 2 16
 TEXT soft switch 18
 transfer address 31
 280-dot graphics 11, 16
 See also 560-dot graphics
V
 video display page locations,
 table 16
 video displays 16
 video monitor 10
 video display generation 11
W
 write operation 17, 25
 warning 17
 writing memory 21, 25
X
 X and Y registers 30
 XFER subroutine 15, 29, 30
 parameters 31
 warning 31
Z
 zero page 25, 29, 36, 37
 warning when switching 15

Schematic Diagram

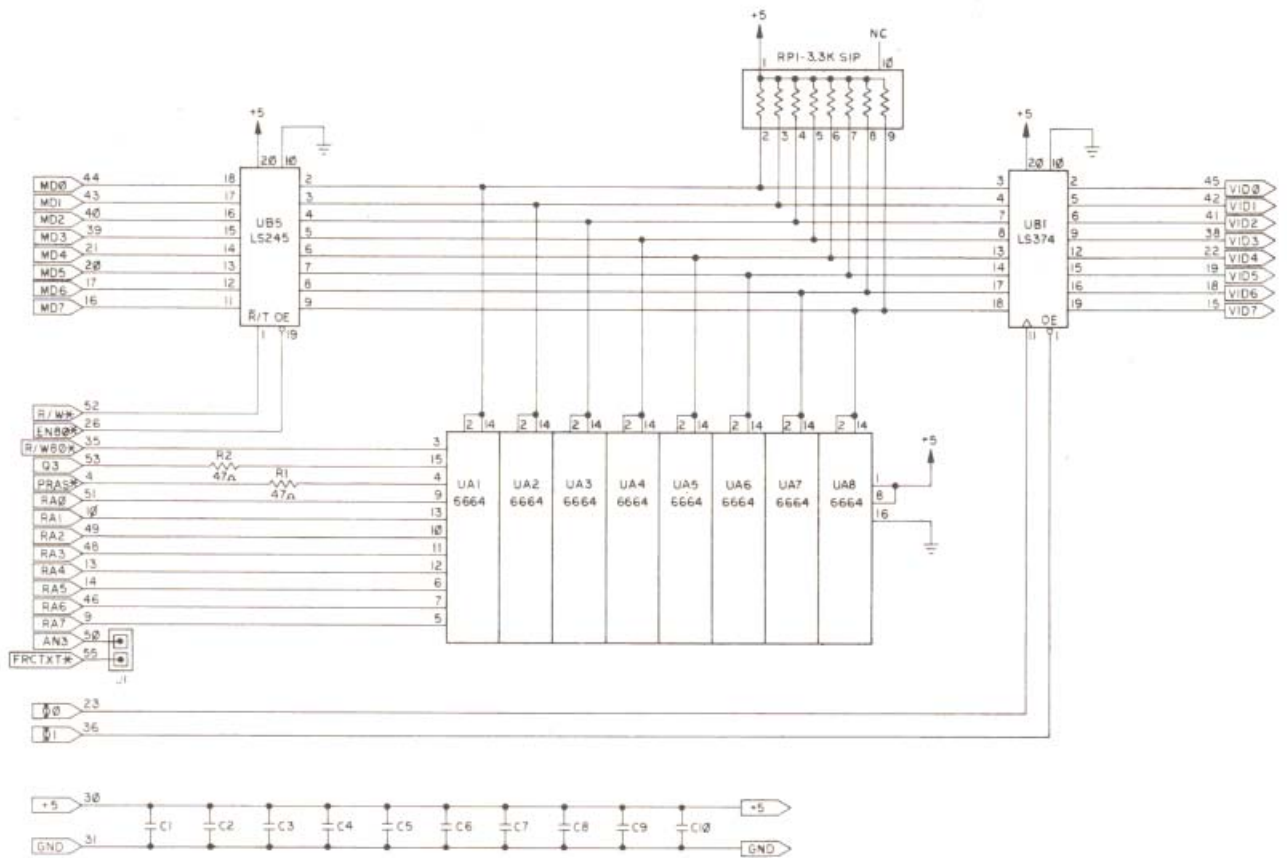



20525 Mariani Avenue
Cupertino, California 95014
(408) 996-1010
TLX 171-576

030-0496-A